

LINEA

5940UAP150P50 RAL7001

EAN 4031582411508



BETTER MOBILITY. BETTER LIFE.



Image may differ from the original product

PERFORMANCE

Roll performance	● ● ● ● ●
Movement noise	● ● ● ● ○
Attrition	● ● ● ● ○
Corrosion resistance	● ● ● ● ○

CORE ATTRIBUTES

Product name	Linea
Type	Swivel castor
Standard	EN12530 - Devices Castors
Load capacity at 1.8 mph	242.51 lb
Load capacity Static	485.02 lb
Temperature range (Minimum)	-4 °F
Temperature range (Maximum)	140 °F
Overall height	6.69 in
Overall width	3.5 in
Overall weight	2.43 lb

WHEEL

Body material	Polyamide
Tread material	Polyurethane, injected
Bearing	Precision ball bearing
Threadguards	With threadguard
Diameter	5.91 in
Tread width	0.87 in
Hardness of tread (A)	92 Shore A

HOUSING

Material	Polyamide
Fork shape	Twin wheel housing
Swivel bearing	Precision ball bearing
Color	Silver gray (RAL7001)
Offset	2.05 in
Swivel radius	5.24 in
Swivel interference	8.58 in
Dome diameter	2.2 in

FITTING

Fitting type	Rectangular plate
Plate length	3.03 in
Plate width	2.64 in
Plate hole length (Minimum)	2.2 in
Plate hole length (Maximum)	2.42 in
Plate hole width (Minimum)	1.83 in
Plate hole width (Maximum)	2.03 in
Plate hole diameter	0.33 in



LINEA

5940UAP150P50 RAL7001

EAN 4031582411508



BETTER MOBILITY. BETTER LIFE.

TECHNICAL DRAWINGS

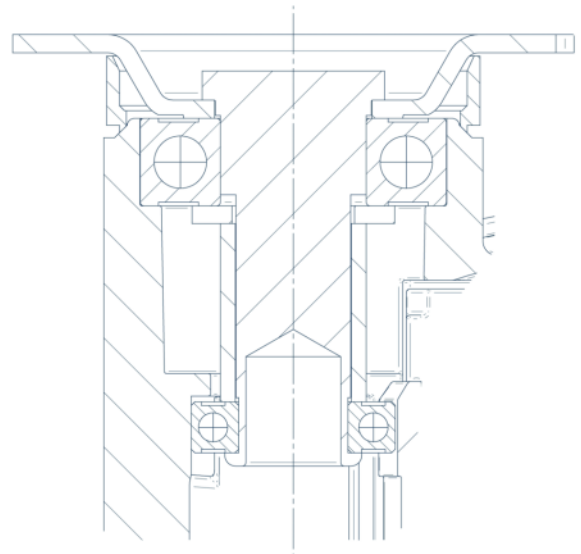
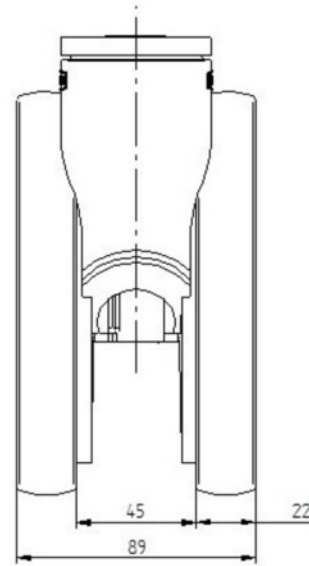
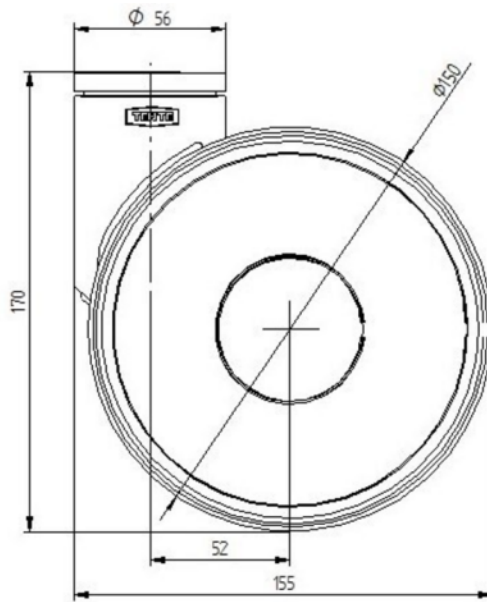

Deutscher
Designer
Club



Interzum
Award



IF
Design
Award