

NOVATECH

ITP160x50-Ø20 HL60 super convex R25

EAN 4031582444667



BETTER MOBILITY. BETTER LIFE.



Afbeelding kan afwijken van het oorspronkelijke product

WIEL

Tread profile	convex
Materiaal wielkern	Aluminium
Materiaal loopvlak	Polyurethaan, Gegoten
Lagering	Precisie kogellagers
Afdekkapjes	Zonder schroefdraadbeschermer
Diameter	160 mm
Breedte Loopvlak	50 mm
Diameter Asgat	20 mm
Naaflengte	60 mm
Hardheid van het Loopvlak (A)	92 Shore A

PRESTATIES

Rolprestaties	● ● ● ● ○
Bewegingsgeluid	● ● ● ● ○
Slijtage	● ● ● ● ● ○
Corrosiebestendigheid	● ● ● ● ○ ○

KERNKENMERKEN

Productnaam	Novatech
Type	Wiel
Standaard	EN12532 - Transportuitrusting
Draagvermogen bij 4 km/h	500 kg
Elektrisch geleidend	Nee
Roestvrij	Nee
Statisch draagvermogen	1000 kg
Temperatuurbereik (minimaal)	-20 °C
Temperatuurbereik (maximaal)	60 °C
Totaal gewicht	1 kg

NOVATECH

ITP160x50-Ø20 HL60 super convex R25

EAN 4031582444667



BETTER MOBILITY. BETTER LIFE.

Product Drawings

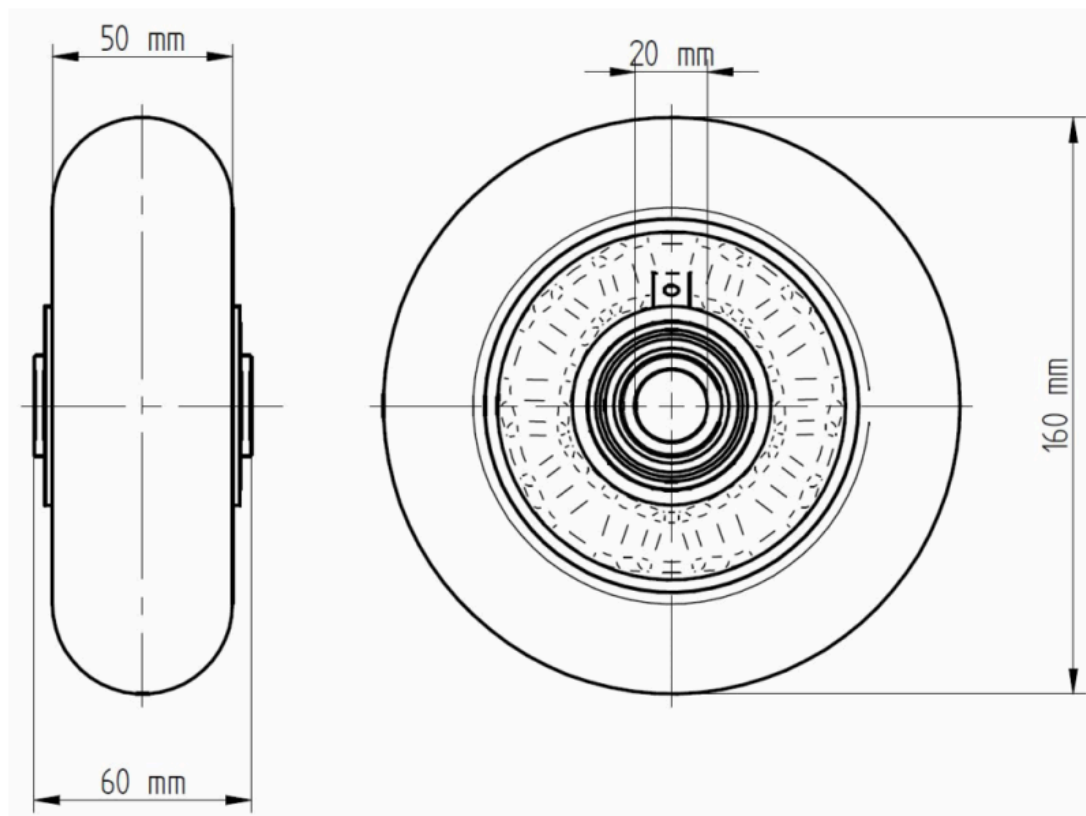

PRODUCTINFORMATIE

NOVATECH

ITP160x50-Q20 HL60 super convex R25

EAN 403158244156

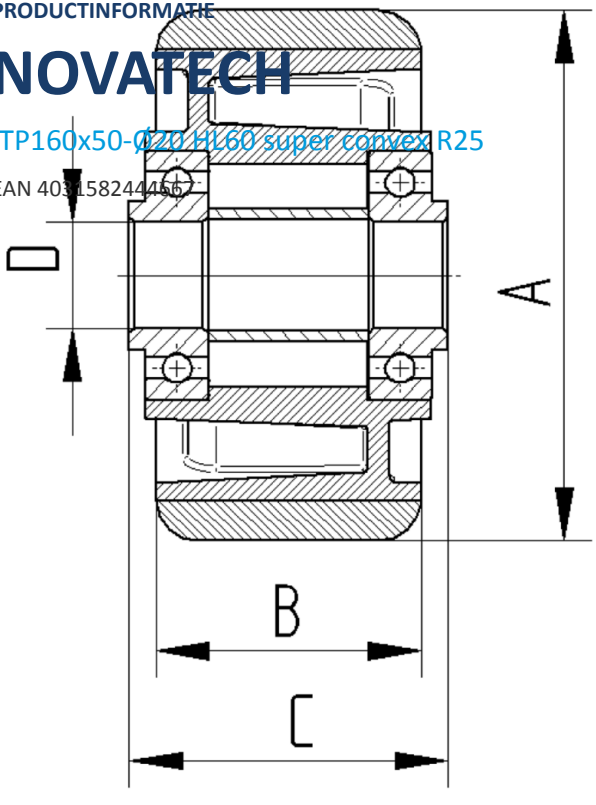

BETTER MOBILITY. BETTER LIFE.