

# LEVINA STAINLESS

5381UAC125P30-11 XL

EAN 4031582382075



BETTER MOBILITY. BETTER LIFE.



Image may differ from the original product

## PERFORMANCE

Roll performance	●●●○○
Movement noise	●●●●●
Attrition	●●●●○
Corrosion resistance	●●●●○

## CORE ATTRIBUTES

Product name	Levina stainless
Type	Swivel castor with directional lock
Standard	EN12530 - Devices Castors
Load capacity at 3 km/h	100 kg
Stainless	✓
Load capacity Static	200 kg
Temperature range (Minimum)	-10 °C
Temperature range (Maximum)	40 °C
Overall height	161 mm
Overall weight	0.662 kg

## WHEEL

Body material	Polyamide
Tread material	Polyurethane, injected
Bearing	Precision ball bearing, stainless
Threadguards	With threadguard
Diameter	125 mm
Tread width	32 mm
Hardness of tread (A)	92 Shore A
Hardness of tread (D)	40 Shore D

## HOUSING

Material fork	Polyamide
Fork shape	Slim
Swivel bearing	Two ball races, reinforced or stainless
Offset	38.5 mm
Swivel radius	130 mm
Swivel interference	260 mm

## FITTING

Fitting type	Bolt hole
Bolt hole diameter	11 mm



# LEVINA STAINLESS

5381UAC125P30-11 XL

EAN 4031582382075



BETTER MOBILITY. BETTER LIFE.

## TECHNICAL DRAWINGS

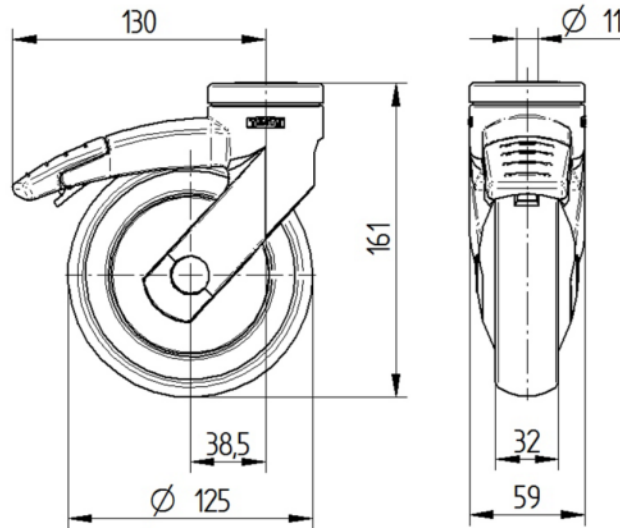

Universal  
Design  
Award



Deutscher  
Designer  
Club