

# LEVINA

5371PIP100R05-28X45

EAN 4031582362886



BETTER MOBILITY. BETTER LIFE.



Image may differ from the original product

## PERFORMANCE

Roll performance	● ● ● ○ ○
Movement noise	● ● ● ● ●
Attrition	● ● ● ○ ○
Corrosion resistance	● ● ● ● ●

## CORE ATTRIBUTES

Product name	Levina
Type	Swivel castor with directional lock
Standard	EN12530 - Devices Castors
Load capacity at 3 km/h	80 kg
Load capacity Static	160 kg
Temperature range (Minimum)	-10 °C
Temperature range (Maximum)	40 °C
Overall height	137 mm

## WHEEL

Body material	Polypropylene
Tread hardness	soft
Tread material	Solid rubber, non-marking
Bearing	Precision ball bearing
Threadguards	With threadguard
Diameter	100 mm
Tread width	32 mm
Hardness of tread (A)	75 Shore A

## HOUSING

Material fork	Polyamide
Fork shape	Slim
Swivel bearing	Two ball races
Offset	36 mm
Swivel radius	98 mm
Swivel interference	196 mm

## FITTING

Fitting type	Solid stem, round
Bolt diameter	28 mm
Bolt length	45 mm



Universal Design Award



Deutscher Designer Club

# LEVINA

5371PIP100R05-28X45

EAN 4031582362886



BETTER MOBILITY. BETTER LIFE.

## TECHNICAL DRAWINGS

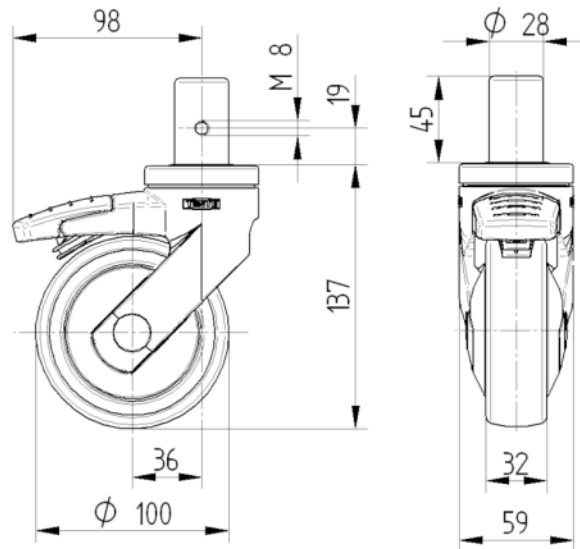

Universal  
Design  
Award



Deutscher  
Designer  
Club