

PRODUCT INFORMATION

# NOVATECH

FTP250x50-Ø25 HL62

EAN 4031582331035



BETTER MOBILITY. BETTER LIFE.



Image may differ from the original product

### WHEEL

Body material	Cast iron
Tread Material Mix	Polyurethane, casted
Bearing	Precision ball bearing
Threadguards	With threadguard
Diameter	250 mm
Tread width	50 mm
Axle Hole Diameter	25 mm
Hub Length	62 mm
Hardness of tread (A)	92 Shore A

### PERFORMANCE

Roll Performance	●●●●○
Movement Noise	●●●○○
Attrition	●●●●○
Corrosion Resistance	●●●○○

### CORE ATTRIBUTES

Product Name	Novatech
Type	Wheel
Standard	EN12533 - Heavy Duty Castors
Load capacity at 4 km/h	1440 kg
Load capacity at 6 km/h	1200 kg
Electric Conductive	No
Stainless	No
Load capacity Static	2880 kg
Temperature range (Minimum)	-20 °C
Temperature range (Maximum)	60 °C

# NOVATECH

FTP250x50-Ø25 HL62

EAN 4031582331035



BETTER MOBILITY. BETTER LIFE.

## Product Drawings

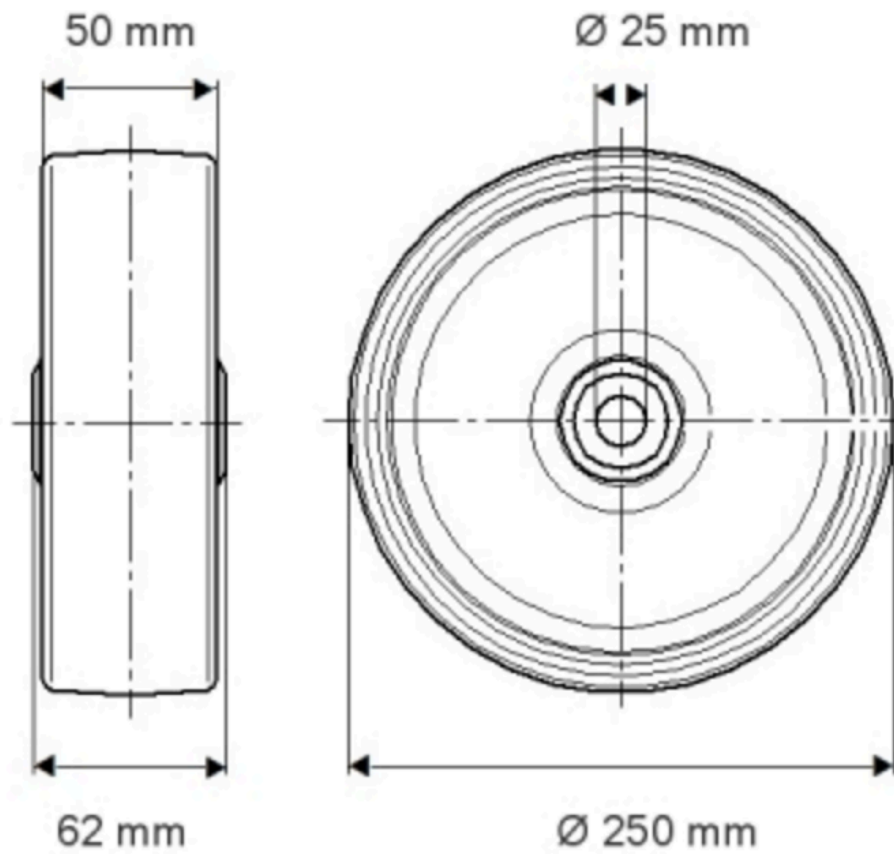

PRODUCT INFORMATION

# NOVATECH

FTP250x50-Ø25 HL62

EAN 4031582381055

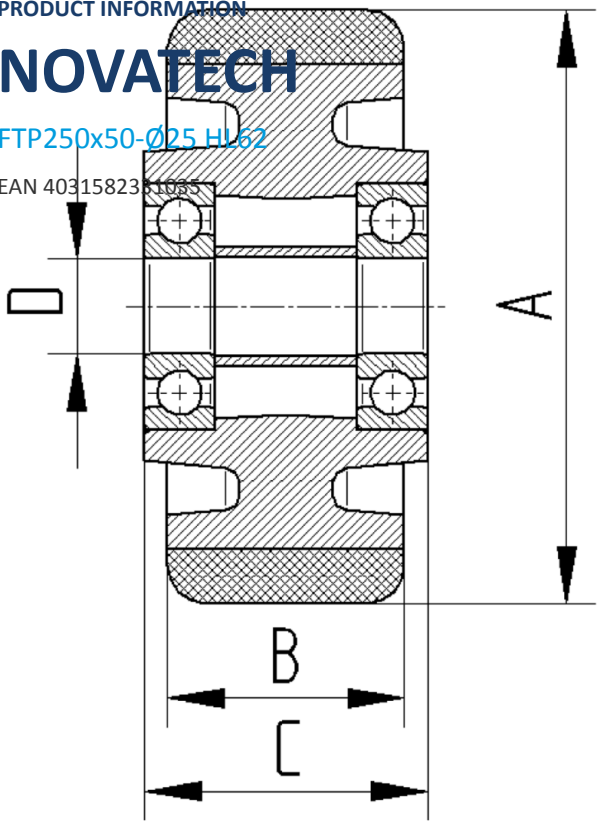

BETTER MOBILITY. BETTER LIFE.