

LINEA LOW HEIGHT

5945UAP100P30-8 LH RAL7001

EAN 4031582373073



BETTER MOBILITY. BETTER LIFE.

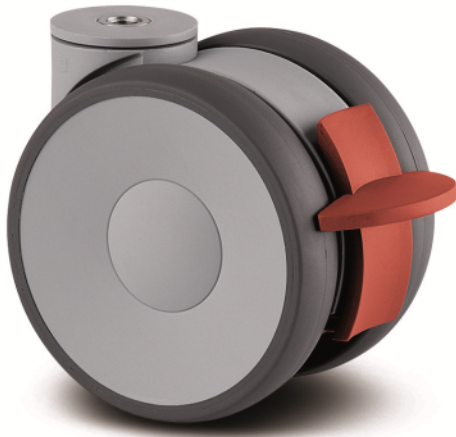

Image may differ from the original product

PERFORMANCE

Roll performance	● ● ● ● ●
Movement noise	● ● ● ○ ○
Attrition	● ● ● ● ○
Corrosion resistance	● ● ● ● ○

CORE ATTRIBUTES

Product name	Linea low height
Type	Swivel castor with wheel brake
Standard	EN12530 - Devices Castors
Load capacity at 3 km/h	100 kg
Load capacity Static	200 kg
Temperature range (Minimum)	-10 °C
Temperature range (Maximum)	40 °C
Overall height	103 mm
Overall width	73 mm

WHEEL

Body material	Polyamide
Tread material	Polyurethane, injected
Bearing	Precision ball bearing
Threadguards	With threadguard
Diameter	100 mm
Tread width	20 mm
Hardness of tread (A)	92 Shore A

HOUSING

Material fork	Polyamide
Fork shape	Twin wheel housing
Swivel bearing	Precision ball bearing
Colour	Silver grey (RAL7001)
Offset	32 mm
Swivel radius	102 mm
Swivel interference	204 mm
Dome diameter	41 mm

FITTING

Fitting type	Bolt hole
Bolt hole diameter	8 mm



Deutscher Designer Club



Interzum Award



IF Design Award

LINEA LOW HEIGHT

5945UAP100P30-8 LH RAL7001

EAN 4031582373073



BETTER MOBILITY. BETTER LIFE.

TECHNICAL DRAWINGS

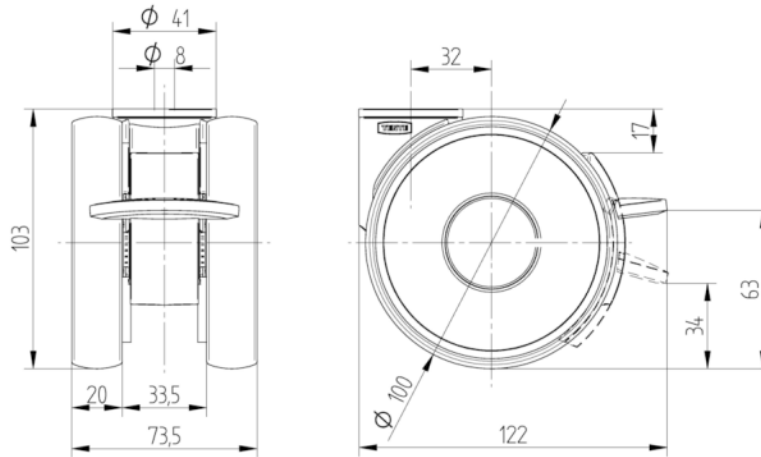

Deutscher
Designer
Club



Interzum
Award



IF
Design
Award