

LINEA LIGHT

5925UAP100L51-11 7001/3000/7015

EAN 4031582350562



BETTER MOBILITY. BETTER LIFE.



Image may differ from the original product

PERFORMANCE

Roll Performance	● ● ● ● ○
Movement Noise	● ● ● ● ○
Attrition	● ● ● ● ○
Corrosion Resistance	● ● ● ● ○

CORE ATTRIBUTES

Product Name	Linea light
Type	Swivel castor with wheel brake
Standard	EN12528 - Furniture Castors
Load capacity at 3 km/h	100 kg
Electric Conductive	No
Stainless	No
Load capacity Static	200 kg
Temperature range (Minimum)	-10 °C
Temperature range (Maximum)	40 °C
Overall Height	100 mm
Overall width	73 mm
Overall weight	0.44 kg

HOUSING

Housing Material	Polyamide
Fork shape	Twin wheel housing
Swivel Bearing	Stem, swiveling
Housing Color	Silver grey (RAL7001)
Offset	32 mm
Swivel radius	102 mm
Swivel interference	204 mm
Dome diameter	41 mm

WHEEL

Body material	Polyamide
Tread Material Mix	Polyurethane, injected
Bearing	Precision ball bearing
Tread Color	Slate grey (RAL7015)
Wheel Color	Slate grey (RAL7015)
Threadguards	With threadguard
Diameter	100 mm
Tread width	20 mm
Axle Hole Diameter	0 mm
Hub Length	0 mm
Body width	20 mm
Hardness of tread (A)	92 Shore A

FITTING

Fitting type	Blind hole for B10
Bolt hole diameter	11 mm



Deutscher Designer Club



Interzum Award



IF Design Award



LINEA LIGHT

5925UAP100L51-11 7001/3000/7015

EAN 4031582350562

Order number 00770455
Product Drawings



BETTER MOBILITY. BETTER LIFE.

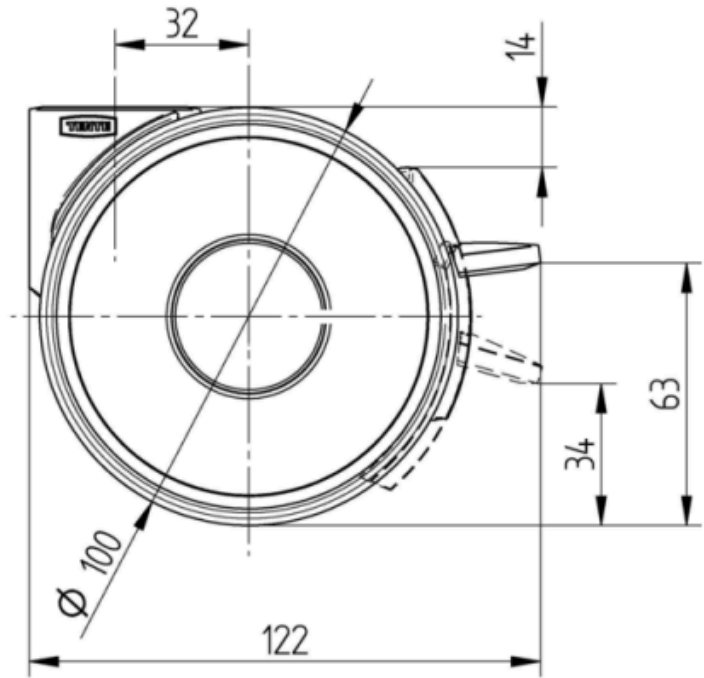
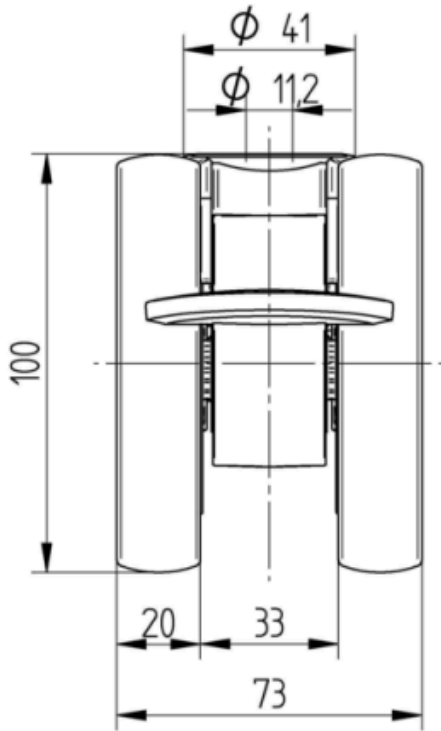

Deutscher Designer Club



Interzum Award



product design award

IF Design Award