

# LINEA LOAD

5945UAP050L51-8 LOAD 9011

EAN 4031582421620



BETTER MOBILITY. BETTER LIFE.



Afbeelding kan afwijken van het oorspronkelijke product

## PRESTATIES

Rolprestaties	● ● ● ● ●
Bewegingsgeluid	● ● ● ● ○
Slijtage	● ● ● ● ●
Corrosiebestendigheid	● ● ● ● ○

## KERNKENMERKEN

Productnaam	Linea load
Type	Wielen met Wielslot
Standaard	EN12530 - Hulpmiddelen zwenkwielen
Draagvermogen bij 3 km/h	100 kg
Statisch draagvermogen	200 kg
Temperatuurbereik (minimaal)	-10 °C
Temperatuurbereik (maximaal)	40 °C
Totale hoogte	50 mm
Totale breedte	47,5 mm
Totaal gewicht	0,092 kg

## WIEL

Materiaal wielkern	Polyamide
Materiaal loopvlak	Polyurethaan, Gespoten
Lagering	Precisie kogellagers
Afdekkapjes	Met draadbeschermer
Diameter	50 mm
Breedte Loopvlak	13 mm
Hardheid van het Loopvlak (A)	92 Shore A

## BEHUIZING

Materiaal	Polyamide
Vork Vorm	Behuizing met twee Wiel
Zwenklager	Precisie kogellagers
Kleur	Grafietzwart (RAL9011)
Zwenk radius	51 mm
Draaicirkel	102 mm
Diameter koepel	23 mm

## FITTING

Type bevestiging	Blind gat voor B10-fitting
Boutgat diameter	8 mm

Deutscher  
Ontwerper  
ClubInterzum  
AwardIF  
Design  
Award

# LINEA LOAD

5945UAP050L51-8 LOAD 9011

EAN 4031582421620



BETTER MOBILITY. BETTER LIFE.

## TECHNISCHE TEKENINGEN

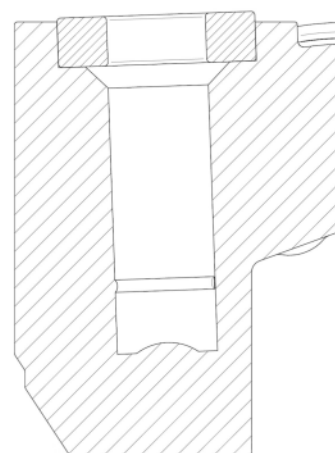
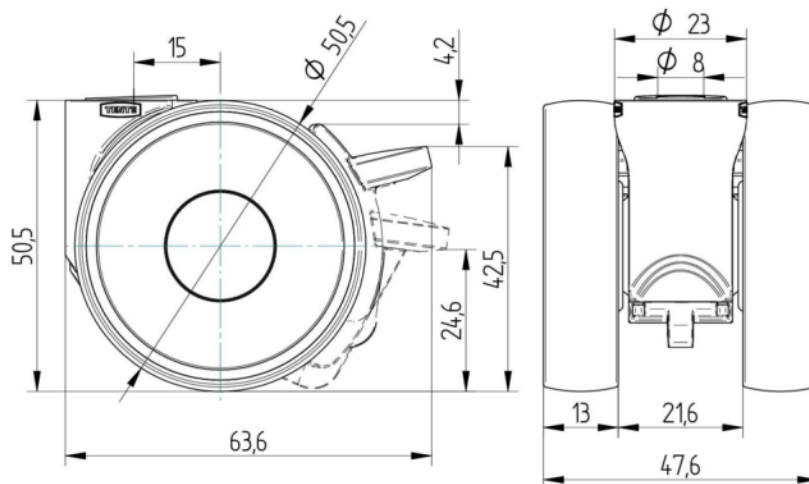

Deutscher  
Ontwerper  
Club



Interzum  
Award



IF  
Design  
Award