

# LEVINA

5371PIP125P51

EAN 4031582362923



BETTER MOBILITY. BETTER LIFE.



Image may differ from the original product

## PERFORMANCE

Roll performance	●●●○○
Movement noise	●●●●●
Attrition	●●●○○
Corrosion resistance	●●●●●

## CORE ATTRIBUTES

Product name	Levina
Type	Swivel castor with directional lock
Standard	EN12530 - Devices Castors
Load capacity at 3 km/h	100 kg
Load capacity Static	200 kg
Temperature range (Minimum)	-10 °C
Temperature range (Maximum)	40 °C
Overall height	165 mm

## WHEEL

Body material	Polypropylene
Tread hardness	soft
Tread material	Solid rubber, non-marking
Bearing	Precision ball bearing
Threadguards	With threadguard
Diameter	125 mm
Tread width	32 mm
Hardness of tread (A)	75 Shore A

## HOUSING

Material fork	Polyamide
Fork shape	Slim
Swivel bearing	Two ball races
Offset	38 mm
Swivel radius	100.5 mm
Swivel interference	201 mm

## FITTING

Fitting type	Rectangular plate
Plate length	95 mm
Plate width	70 mm
Plate hole length (Maximum)	75 mm
Plate hole width (Maximum)	50 mm
Plate hole diameter	11 mm



Universal Design Award



Deutscher Designer Club

# LEVINA

5371PIP125P51

EAN 4031582362923



BETTER MOBILITY. BETTER LIFE.

## TECHNICAL DRAWINGS

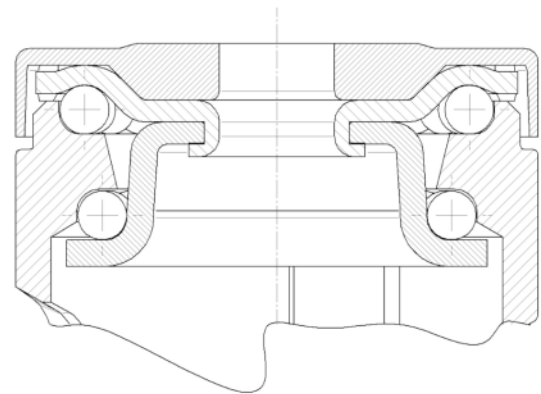
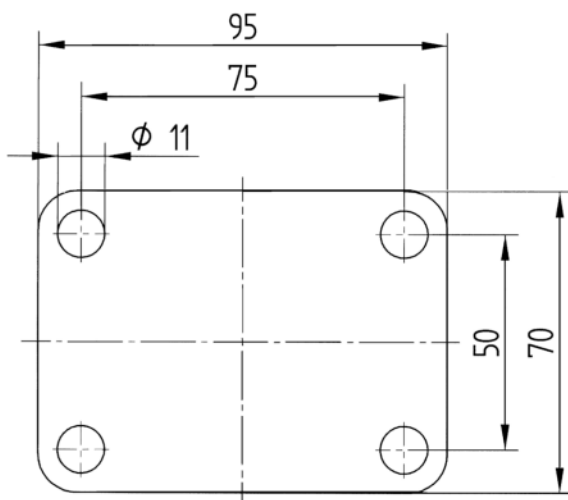
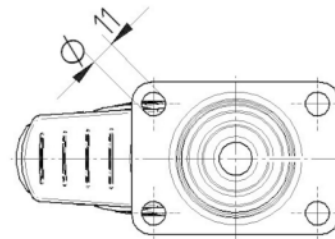
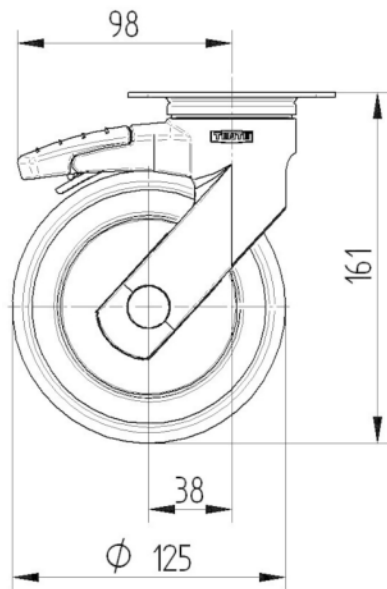

Universal  
Design  
Award



Deutscher  
Designer  
Club