

# LINEA

5941XSC100R05-28 RAL9002

EAN 4031582352863



BETTER MOBILITY. BETTER LIFE.



Image may differ from the original product

## PERFORMANCE

Roll performance	● ● ● ● ●
Movement noise	● ● ● ○ ○
Attrition	● ● ● ● ○
Corrosion resistance	● ● ● ● ○

## CORE ATTRIBUTES

Product name	Linea
Type	Swivel castor with directional lock
Standard	EN12530 - Devices Castors
Load capacity at 3 km/h	120 kg
Electric conductive	✓
Stainless	✓
Load capacity Static	240 kg
Temperature range (Minimum)	-10 °C
Temperature range (Maximum)	40 °C
Overall height	120 mm
Overall width	82 mm
Overall weight	0.93 kg

## WHEEL

Body material	Polyamide, electric conductive
Tread material	Polyurethane, injected, electric-conductive
Bearing	Precision ball bearing, stainless
Threadguards	With threadguard
Diameter	100 mm
Tread width	20 mm
Hardness of tread (A)	92 Shore A

## HOUSING

Material fork	Polyamide
Fork shape	Twin wheel housing
Swivel bearing	Precision ball bearing
Colour	Grey white (RAL9002)
Offset	32 mm
Swivel radius	108 mm
Swivel interference	216 mm
Dome diameter	52 mm

## FITTING

Fitting type	Solid stem, round
Bolt diameter	28 mm
Bolt length	40 mm



Deutscher Designer Club



Interzum Award



IF Design Award

# LINEA

5941XSC100R05-28 RAL9002

EAN 4031582352863



BETTER MOBILITY. BETTER LIFE.

## TECHNICAL DRAWINGS

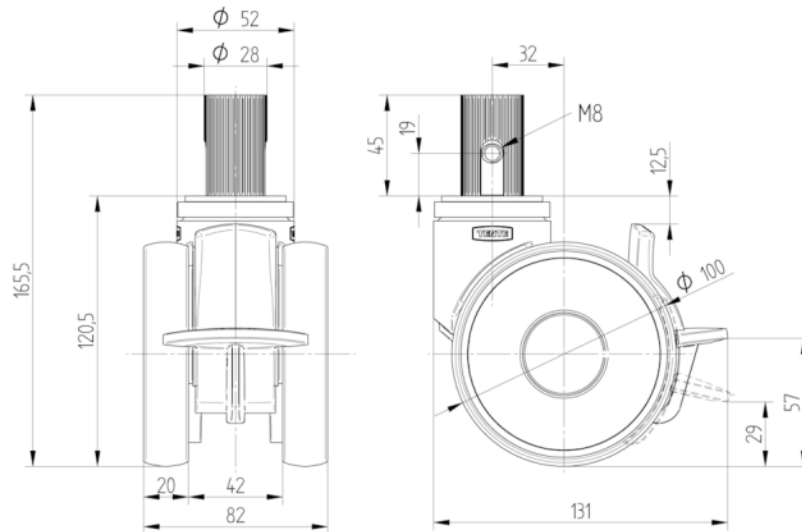

Deutscher  
Designer  
Club



Interzum  
Award



IF  
Design  
Award