

NOVATECH

ITP 160x50-Ø20 HL60 soft cv

EAN 4031582329544



BETTER MOBILITY. BETTER LIFE.



Afbeelding kan afwijken van het oorspronkelijke product

WIEL

Tread profile	convex
Tread hardness	zacht
Materiaal wielkern	Aluminium
Materiaal loopvlak	Polyurethaan, Gegoten
Lagering	Precisie kogellagers
Wielkleur	Verkeersgrijs A (RAL7042)
Afdekkapjes	Zonder schroefdraadbeschermer
Diameter	160 mm
Breedte Loopvlak	50 mm
Diameter Asgat	20 mm
Naaflengte	60 mm
Breedte wielkern	50 mm
Hardheid van het Loopvlak (A)	80 Shore A

PRESTATIES

Rolprestaties	● ● ● ● ○
Bewegingsgeluid	● ● ● ● ○
Slijtage	● ● ● ● ○
Corrosiebestendigheid	● ● ● ○ ○

KERNKENMERKEN

Productnaam	Novatech
Type	Wiel
Standaard	EN12532 - Transportuitrusting
Draagvermogen bij 4 km/h	550 kg
Draagvermogen bij 6 km/h	440 kg
Elektrisch geleidend	Nee
Roestvrij	Nee
Statisch draagvermogen	1100 kg
Temperatuurbereik (minimaal)	-10 °C
Temperatuurbereik (maximaal)	60 °C
Totaal gewicht	1,2 kg

NOVATECH

ITP 160x50-Ø20 HL60 soft cv

EAN 4031582329544

Bestelnummer 00835312
Product Drawings



BETTER MOBILITY. BETTER LIFE.

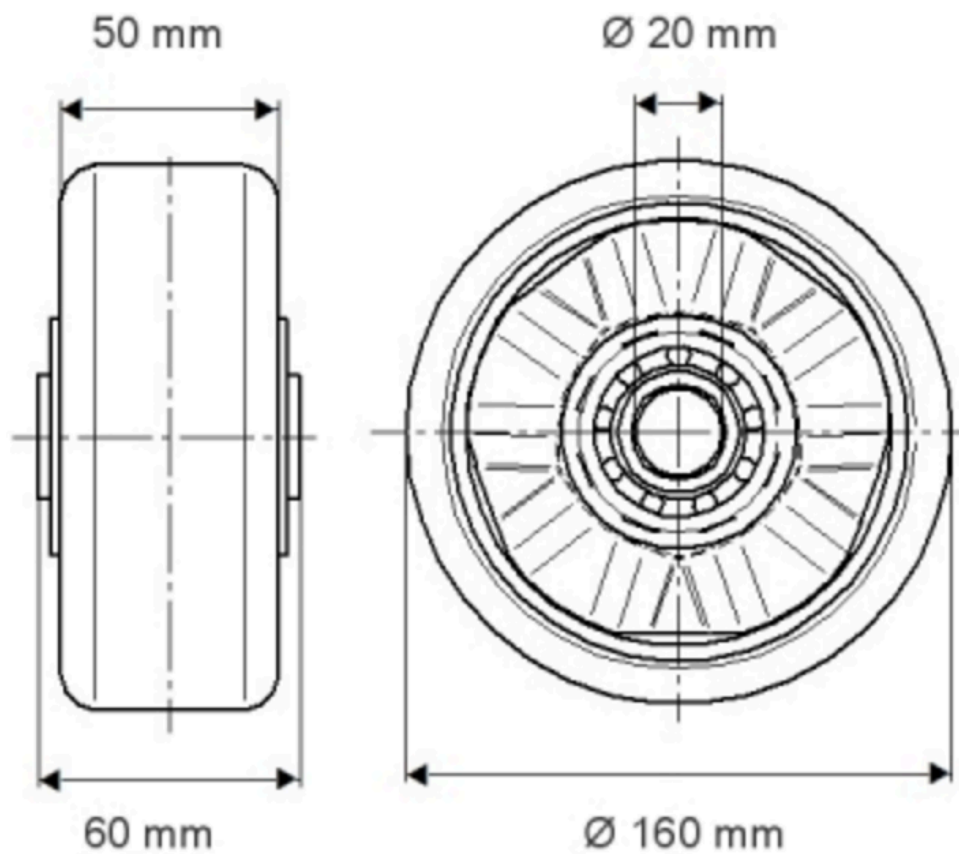

NOVATECH

ITP 160x50-Ø23, HV6050H cv

EAN 4031582329544

Bestelnummer 00885512

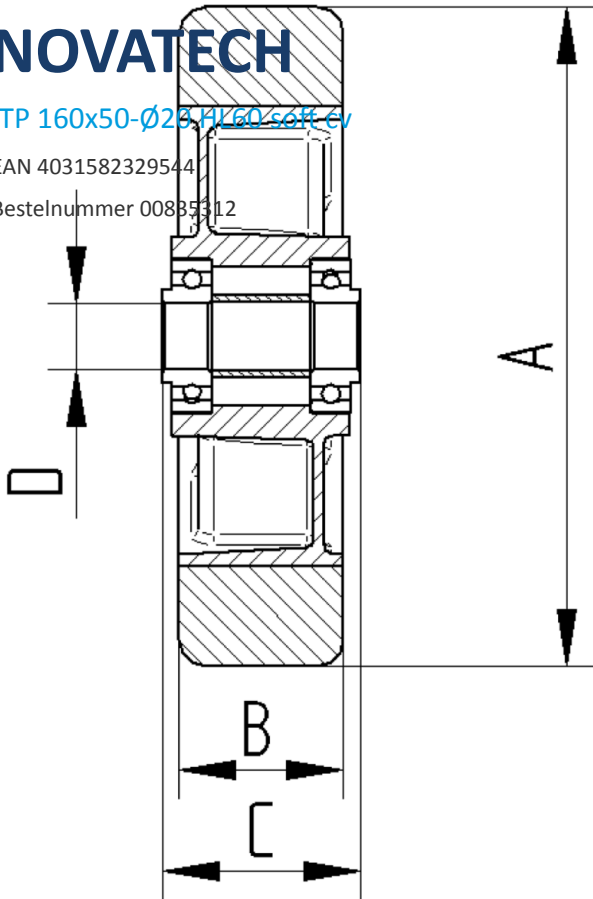

BETTER MOBILITY. BETTER LIFE.