

PRODUCT INFORMATION

# NOVATECH

FTP 300x80-Ø35 HL90

EAN 4031582377125



BETTER MOBILITY. BETTER LIFE.



Image may differ from the original product

### WHEEL

Body material	Casting
Tread material	Polyurethane, casted
Bearing	Precision ball bearing
Wheel color	Honey yellow (RAL1005)
Threadguards	With threadguard
Diameter	11.81 in
Tread width	3.15 in
Axle hole diameter	1.38 in
Hub length	3.54 in
Body width	3.15 in
Hardness of tread (A)	92 Shore A
Hardness of tread (D)	42 Shore D

### PERFORMANCE

Roll Performance	●●●●○
Movement noise	●●●○○
Attrition	●●●●○
Corrosion resistance	●●●○○

### CORE ATTRIBUTES

Product name	Novatech
Type	Wheel
Standard	EN12533 - Heavy Duty Castors
Load capacity at 2.5 mph	5291.09 lb
Load capacity at 3.7 mph	4409.24 lb
Electric conductive	no
Stainless	no
Load capacity Static	8818.48 lb
Temperature range (Minimum)	14 °F
Temperature range (Maximum)	140 °F
Overall weight	32.67 lb

# NOVATECH

FTP 300x80-Ø35 HL90

EAN 4031582377125

Order number 00838840  
Product Drawings



BETTER MOBILITY. BETTER LIFE.

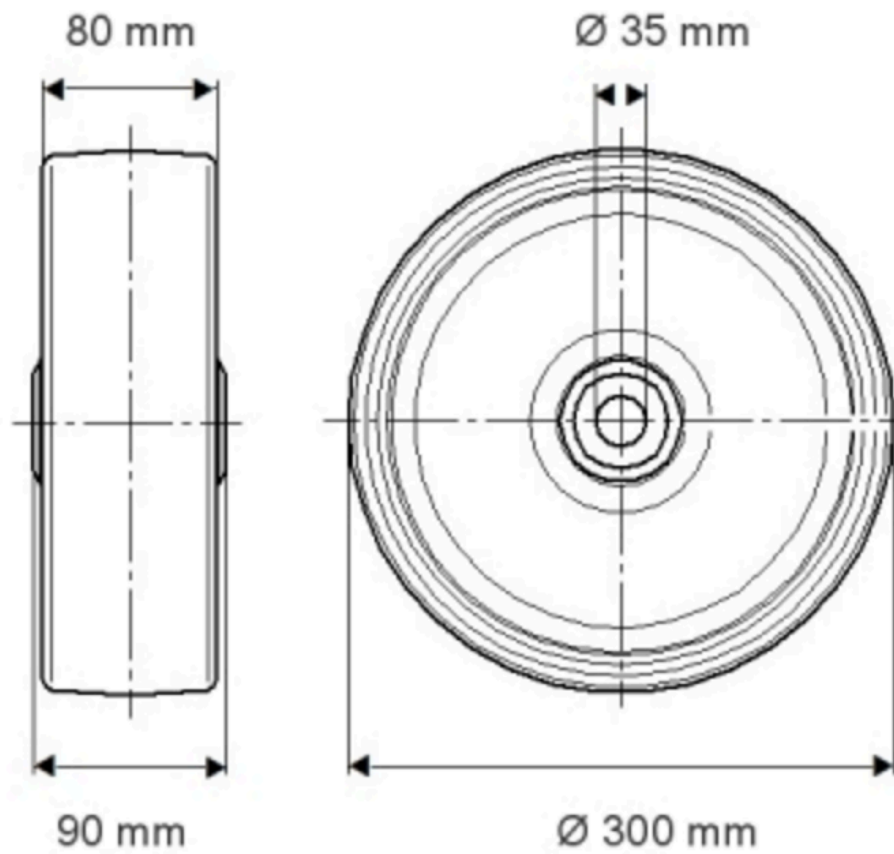

PRODUCT INFORMATION

# NOVATECH

FTP 300x80-035 H190

EAN 4031582377125

Order number 00838840

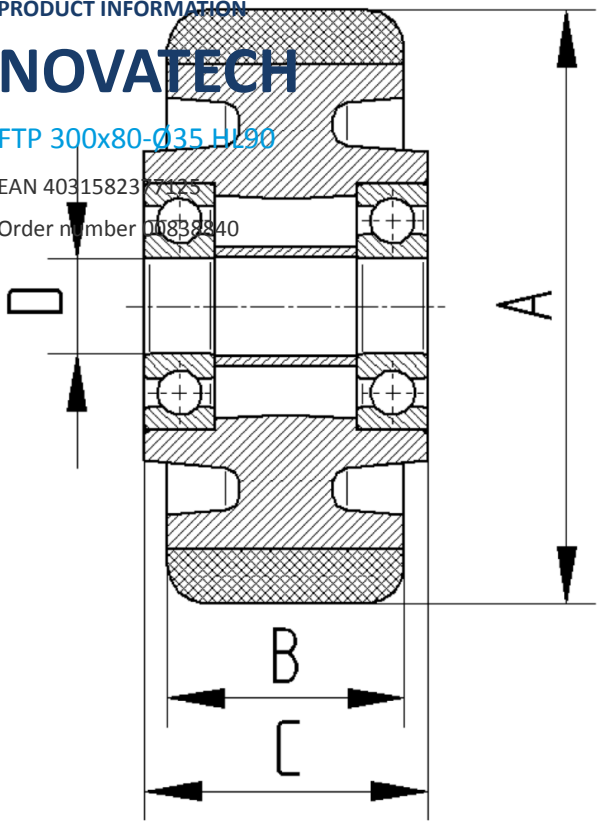

BETTER MOBILITY. BETTER LIFE.