

# LINEA SAFETY

592DUAP100L51-11 7001/7015

EAN 4031582399363



BETTER MOBILITY. BETTER LIFE.



Image may differ from the original product

## PERFORMANCE

Roll Performance	● ● ● ● ○ ○
Movement noise	● ● ● ● ○ ○
Attrition	● ● ● ● ○ ○
Corrosion resistance	● ● ● ● ○ ○

## CORE ATTRIBUTES

Product name	Linea safety
Type	Automatic locking system
Standard	EN12528 - Furniture Castors
Load capacity at 1.8 mph	220.46 lb
Electric conductive	no
Stainless	no
Load capacity Static	440.92 lb
Temperature range (Minimum)	-4 °F
Temperature range (Maximum)	140 °F
Overall height	3.94 in
Overall width	2.87 in
Overall weight	0.89 lb

## HOUSING

Housing Material	Polyamide
Fork shape	Twin wheel housing
Swivel bearing	Stem, swiveling
Housing Color	Silver gray (RAL7001)
Offset	1.26 in
Swivel radius	3.46 in
Swivel interference	6.93 in
Dome diameter	1.61 in

## WHEEL

Body material	Polyamide
Tread material	Polyurethane, injected
Bearing	Precision ball bearing
Tread color	Slate gray (RAL7015)
Wheel color	Slate gray (RAL7015)
Threadguards	With threadguard
Diameter	3.94 in
Tread width	0.79 in
Axle hole diameter	0 in
Hub length	0 in
Body width	0.79 in
Hardness of tread (A)	92 Shore A

## FITTING

Fitting type	Blind hole for B10 fitting
Bolt hole diameter	0.43 in



Deutscher Designer Club



Interzum Award



IF Design Award

product design award

# LINEA SAFETY

592DUAP100L51-11 7001/7015

EAN 4031582399363

Order number 00771682  
Product Drawings



BETTER MOBILITY. BETTER LIFE.

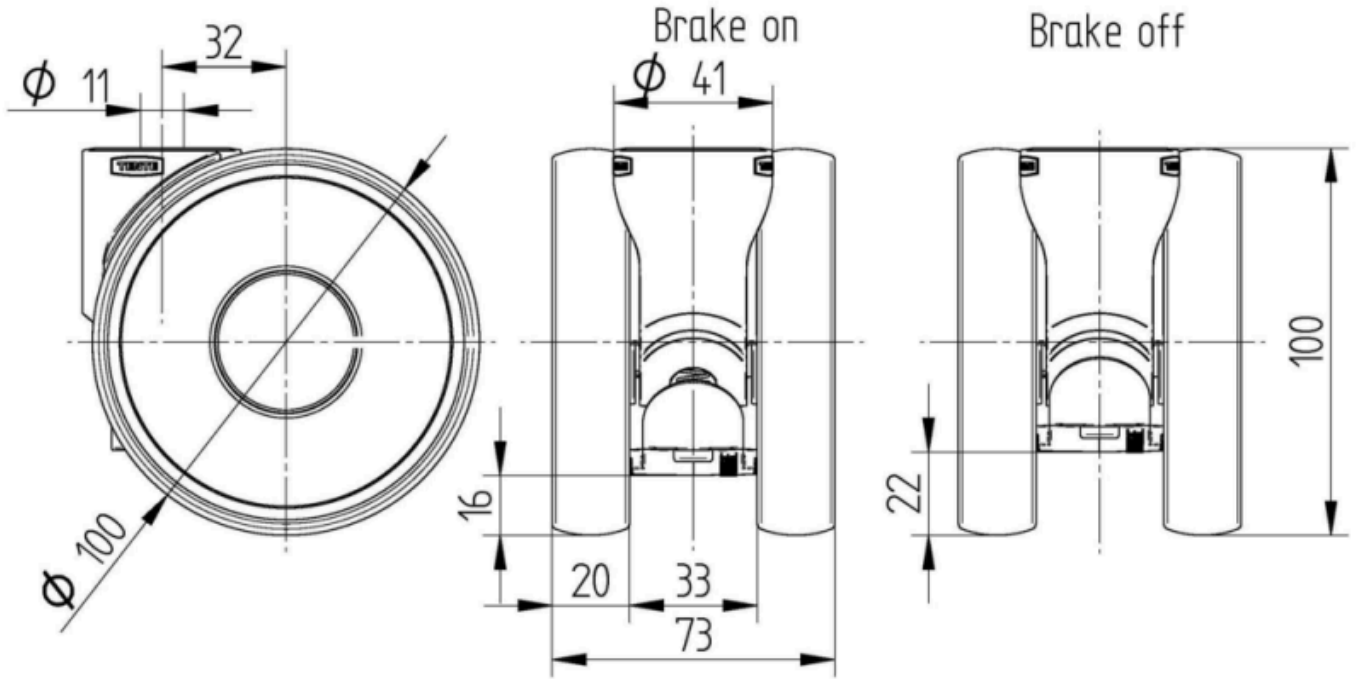

Deutscher  
Designer  
Club



Interzum  
Award



product  
design  
award

IF Design  
Award