

## LINEA

5940UAP150P50

EAN 4031582408911



BETTER MOBILITY. BETTER LIFE.



Afbeelding kan verschillen van het oorspronkelijke product

## PRESTATIES

Rolprestaties ●●●●●

Bewegingsgeluid ●●●●○

Verloop ●●●●○

Corrosieweerstand ●●●●○

## KERNKENMERKEN

Productnaam	Linea
Type	Zwenkwiel
Standaard	EN12530 - Apparaten zwenkwielen
Draagvermogen bij 3 km/u	110 kg
Statisch Draagvermogen	220 kg
Temperatuurbereik (minimaal)	-20 °C
Temperatuurbereik (maximaal)	60 °C
Totale hoogte	170 mm
Totale breedte	89 mm
Totaal gewicht	1,1 kg

## WIEL

Wielkern materiaal	Polyamide
Materiaal loopvlak	Polyurethaan, Gespoten
Lager	Precisiekogellagers
Afdekkapjes	Met afdekkapjes
Diameter	150 mm
Breedte Loopvlak	22 mm
Hardheid van het loopvlak (A)	92 Shore A

## VORK

Materiaal	Polyamide
Vork Vorm	Dubbele vorkwiel
Zwenklager	Precisiekogellagers
Offset	52 mm
Zwenk radius	133 mm
Uitzwenking	218 mm
Diameter koepel	56 mm

## BEVESTIGING

Type bevestiging	Rechthoekige plaat
Lengte plaat	77 mm
Breedte plaat	67 mm
Lengte bevestigingsgat (minimaal)	56 mm
Lengte bevestigingsgat (maximaal)	61,5 mm
Breedte bevestigingsgat (minimaal)	46,5 mm
Breedte bevestigingsgat (maximaal)	51,5 mm
Diameter bevestigingsgat	8,5 mm

Duitse  
OntwerpersClubInterzum  
AwardIF  
Design  
Award

# LINEA

5940UAP150P50

EAN 4031582408911



BETTER MOBILITY. BETTER LIFE.

## TECHNISCHE TEKENINGEN

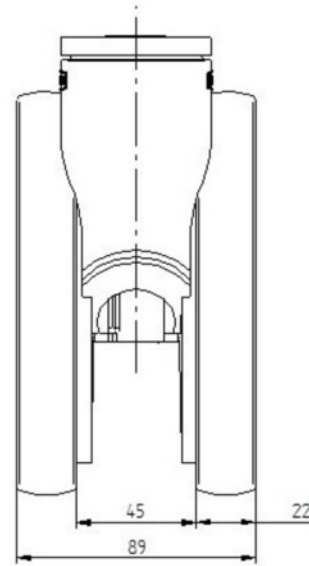
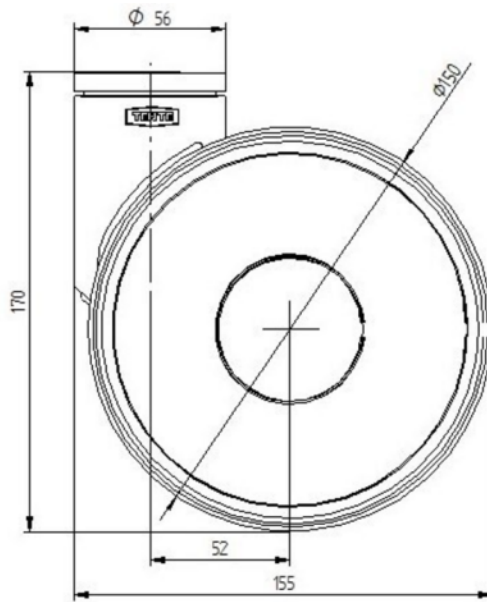

Duitse  
OntwerpersClub



Interzum  
Award



IF  
Design  
Award