

# LINEA

5941UAC125P30-13 RAL9002

EAN 4031582360202



BETTER MOBILITY. BETTER LIFE.



Image may differ from the original product

## PERFORMANCE

Roll performance	● ● ● ● ●
Movement noise	● ● ● ○ ○
Attrition	● ● ● ● ○
Corrosion resistance	● ● ● ● ○

## CORE ATTRIBUTES

Product name	Linea
Type	Swivel castor with directional lock
Standard	EN12530 - Devices Castors
Load capacity at 1.8 mph	286.6 lb
Stainless	✓
Load capacity Static	573.2 lb
Temperature range (Minimum)	14 °F
Temperature range (Maximum)	104 °F
Overall height	5.63 in
Overall width	3.23 in
Overall weight	1.92 lb

## WHEEL

Body material	Polyamide
Tread material	Polyurethane, injected
Bearing	Precision ball bearing, stainless
Threadguards	With threadguard
Diameter	4.92 in
Tread width	0.79 in
Hardness of tread (A)	92 Shore A

## HOUSING

Material	Polyamide
Fork shape	Twin wheel housing
Swivel bearing	Precision ball bearing
Color	Gray white (RAL9002)
Offset	1.57 in
Swivel radius	5.08 in
Swivel interference	10.16 in
Dome diameter	2.05 in

## FITTING

Fitting type	Bolt hole
Bolt hole diameter	0.51 in



# LINEA

5941UAC125P30-13 RAL9002

EAN 4031582360202



BETTER MOBILITY. BETTER LIFE.

## TECHNICAL DRAWINGS

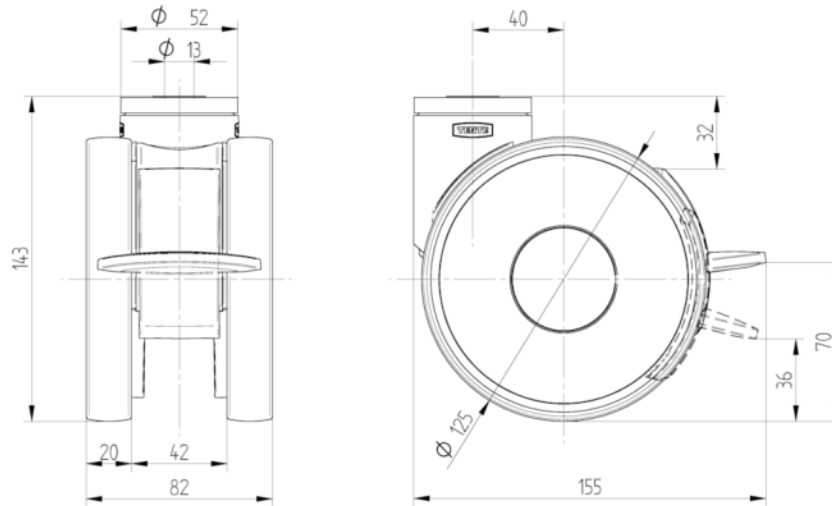

Deutscher  
Designer  
Club



Interzum  
Award



IF  
Design  
Award