

LINEA

5940UAP100P51 RAL9002

EAN 4031582352108



BETTER MOBILITY. BETTER LIFE.



Afbeelding kan verschillen van het oorspronkelijke product

PRESTATIES

Rolprestaties	● ● ● ● ●
Bewegingsgeluid	● ● ● ○ ○
Verloop	● ● ● ● ○
Corrosieweerstand	● ● ● ● ○

KERNKENMERKEN

Productnaam	Linea
Type	Zwenkwiel
Standaard	EN12530 - Apparaten zwenkwielen
Draagvermogen bij 3 km/u	120 kg
Statisch Draagvermogen	240 kg
Temperatuurbereik (minimaal)	-10 °C
Temperatuurbereik (maximaal)	40 °C
Totale hoogte	124 mm
Totale breedte	82 mm

WIEL

Wielkern materiaal	Polyamide
Materiaal loopvlak	Polyurethaan, Gespoten
Lager	Precisiekogellagers
Afdekkapjes	Met afdekkapjes
Diameter	100 mm
Breedte Loopvlak	20 mm
Hardheid van het loopvlak (A)	92 Shore A

VORK

Materiaal	Polyamide
Vork Vorm	Dubbele vorkwiel
Zwenklager	Precisiekogellagers
Kleur	Grijs wit (RAL9002)
Offset	32 mm
Zwenk radius	90 mm
Uitzwenking	180 mm
Diameter koepel	52 mm

BEVESTIGING

Type bevestiging	Rechthoekige plaat
Lengte plaat	95 mm
Breedte plaat	70 mm
Lengte bevestigingsgat (maximaal)	75 mm
Breedte bevestigingsgat (maximaal)	50 mm
Diameter bevestigingsgat	11 mm



Duitse OntwerpersClub



Interzum Award



IF Design Award

LINEA

5940UAP100P51 RAL9002

EAN 4031582352108



BETTER MOBILITY. BETTER LIFE.

TECHNISCHE TEKENINGEN

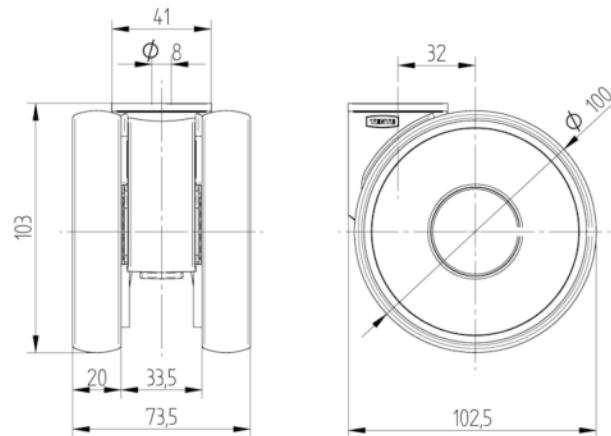

Duitse
OntwerpersClub



Interzum
Award



IF
Design
Award