

LEVINA

5371PJP100P50 7001/6032

EAN 4031582358698
Order number 00038168



BETTER MOBILITY. BETTER LIFE.



Image may differ from the original product

PERFORMANCE

Roll performance	● ● ● ○ ○
Movement noise	● ● ● ● ●
Attrition	● ● ● ○ ○
Corrosion resistance	● ● ● ● ○

CORE ATTRIBUTES

Product name	Levina
Type	Swivel castor with directional lock
Standard	EN12530 - Devices Castors
Load capacity at 1.8 mph	220.46 lb
Load capacity Static	440.92 lb
Temperature range (Minimum)	14 °F
Temperature range (Maximum)	104 °F
Overall height	5.39 in
Overall width	2.32 in
Overall weight	1.11 lb

WHEEL

Body material	Polypropylene
Tread material	Thermoplastic rubber
Bearing	Precision ball bearing
Wheel color	Silver gray (RAL7001)
Threadguards	With threadguard
Diameter	3.94 in
Tread width	1.26 in
Body width	1.26 in
Hardness of tread (A)	87 Shore A

HOUSING

Material	Polyamide
Fork shape	Slim
Swivel bearing	Two ball races
Color	Silver gray (RAL7001)
Offset	1.42 in
Swivel radius	3.86 in
Swivel interference	7.72 in
Dome diameter	2.32 in

FITTING

Fitting type	Rectangular plate
Plate length	3.03 in
Plate width	2.64 in
Plate hole length (Minimum)	1.83 in
Plate hole length (Maximum)	2.03 in
Plate hole width (Minimum)	2.2 in
Plate hole width (Maximum)	2.42 in
Plate hole diameter	0.33 in



Universal Design Award



Deutscher Designer Club

LEVINA

5371PJP100P50 7001/6032

EAN 4031582358698
Order number 00038168



BETTER MOBILITY. BETTER LIFE.

TECHNICAL DRAWINGS

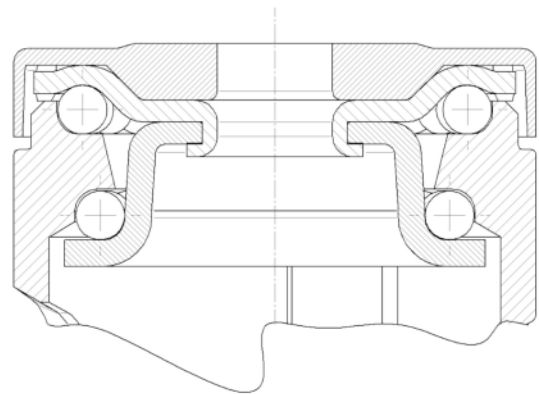
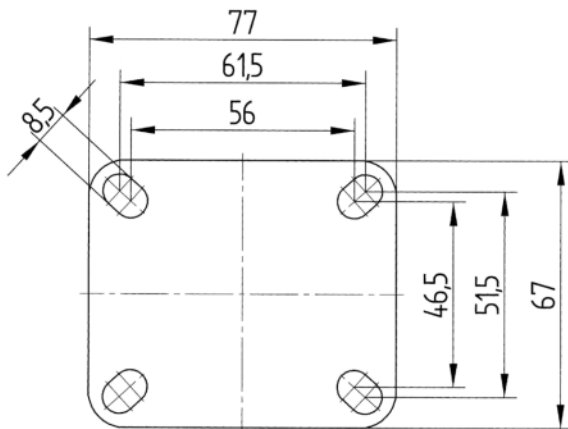
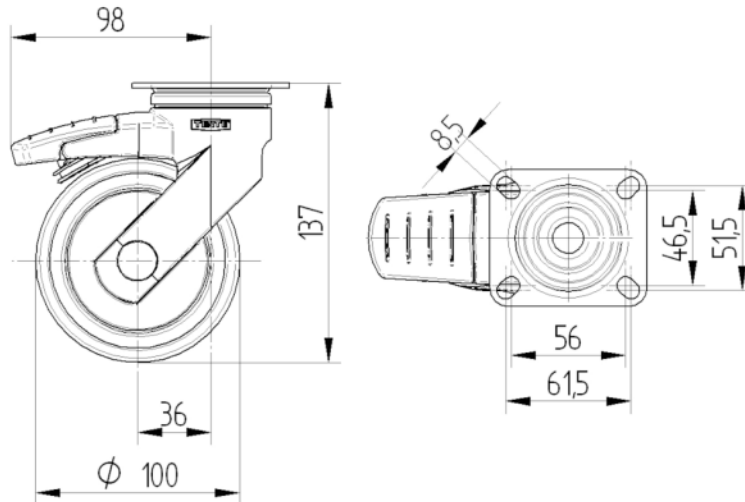

Universal
Design
Award



Deutscher
Designer
Club