

LINEA

5940XSC100R05-28 RAL9002

EAN 4031582352702



BETTER MOBILITY. BETTER LIFE.



Image may differ from the original product

PERFORMANCE

Roll performance	● ● ● ● ●
Movement noise	● ● ● ○ ○
Attrition	● ● ● ● ○
Corrosion resistance	● ● ● ● ○

CORE ATTRIBUTES

Product name	Linea
Type	Swivel castor
Standard	EN12530 - Devices Castors
Load capacity at 1.8 mph	264.55 lb
Electric conductive	✓
Stainless	✓
Load capacity Static	529.11 lb
Temperature range (Minimum)	14 °F
Temperature range (Maximum)	104 °F
Overall height	4.72 in
Overall width	3.23 in
Overall weight	1.82 lb

WHEEL

Body material	Polyamide, electric conductive
Tread material	Polyurethane, injected, electric-conductive
Bearing	Precision ball bearing, stainless
Threadguards	With threadguard
Diameter	3.94 in
Tread width	0.79 in
Hardness of tread (A)	92 Shore A

HOUSING

Material	Polyamide
Fork shape	Twin wheel housing
Swivel bearing	Precision ball bearing
Color	Gray white (RAL9002)
Offset	1.26 in
Swivel radius	3.54 in
Swivel interference	7.09 in
Dome diameter	2.05 in

FITTING

Fitting type	Solid stem, round
Bolt diameter	1.1 in
Bolt length	1.57 in



Deutscher Designer Club



Interzum Award



IF Design Award

LINEA

5940XSC100R05-28 RAL9002

EAN 4031582352702



BETTER MOBILITY. BETTER LIFE.

TECHNICAL DRAWINGS

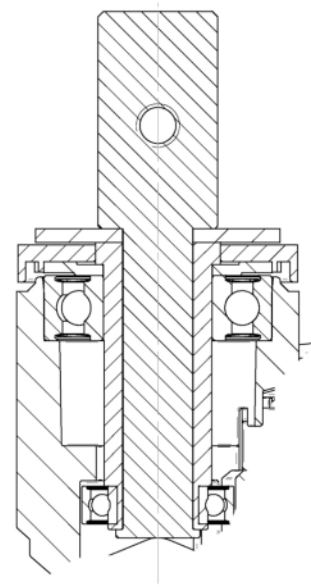
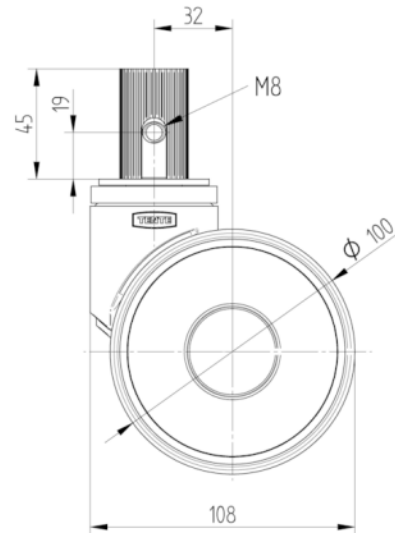
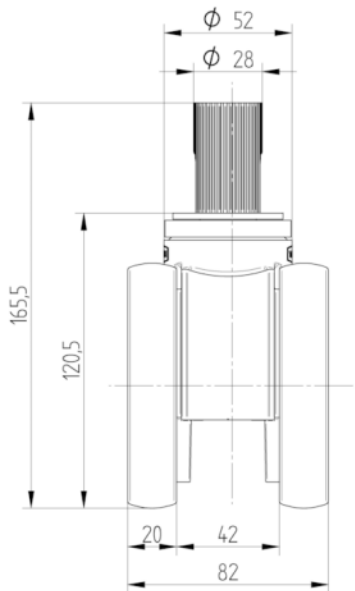

Deutscher
Designer
Club



Interzum
Award



IF
Design
Award