

# LINEA

5941XSP100P51 RAL9002

EAN 4031582352351



BETTER MOBILITY. BETTER LIFE.



Image may differ from the original product

## PERFORMANCE

Roll performance	● ● ● ● ●
Movement noise	● ● ● ○ ○
Attrition	● ● ● ● ○
Corrosion resistance	● ● ● ● ○

## CORE ATTRIBUTES

Product name	Linea
Type	Swivel castor with directional lock
Standard	EN12530 - Devices Castors
Load capacity at 1.8 mph	264.55 lb
Electric conductive	✓
Load capacity Static	529.11 lb
Temperature range (Minimum)	14 °F
Temperature range (Maximum)	104 °F
Overall height	4.88 in
Overall width	3.23 in

## WHEEL

Body material	Polyamide, electric conductive
Tread material	Polyurethane, injected, electric-conductive
Bearing	Precision ball bearing
Threadguards	With threadguard
Diameter	3.94 in
Tread width	0.79 in
Hardness of tread (A)	92 Shore A

## HOUSING

Material	Polyamide
Fork shape	Twin wheel housing
Swivel bearing	Precision ball bearing
Color	Gray white (RAL9002)
Offset	1.26 in
Swivel radius	4.25 in
Swivel interference	8.5 in
Dome diameter	2.05 in

## FITTING

Fitting type	Rectangular plate
Plate length	3.74 in
Plate width	2.76 in
Plate hole length (Maximum)	2.95 in
Plate hole width (Maximum)	1.97 in
Plate hole diameter	0.43 in



Deutscher Designer Club



Interzum Award



IF Design Award

PRODUCT INFORMATION

# LINEA

5941XSP100P51 RAL9002

EAN 4031582352351

TECHNICAL DRAWINGS

---

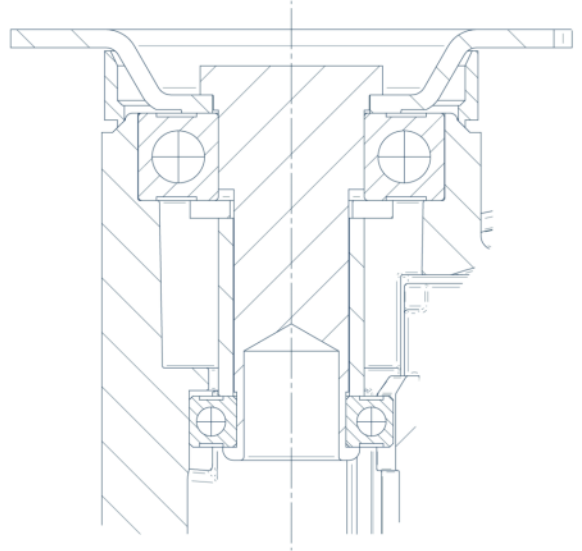

Deutscher  
Designer  
Club



Interzum  
Award



IF  
Design  
Award