

LINEA

5940UAP150P50 RAL7001

EAN 4031582411508



BETTER MOBILITY. BETTER LIFE.



Image may differ from the original product

PERFORMANCE

Roll performance	● ● ● ● ●
Movement noise	● ● ● ● ○
Attrition	● ● ● ● ○
Corrosion resistance	● ● ● ● ○

CORE ATTRIBUTES

Product name	Linea
Type	Swivel castor
Standard	EN12530 - Devices Castors
Load capacity at 3 km/h	110 kg
Load capacity Static	220 kg
Temperature range (Minimum)	-20 °C
Temperature range (Maximum)	60 °C
Overall height	170 mm
Overall width	89 mm
Overall weight	1.1 kg

WHEEL

Body material	Polyamide
Tread material	Polyurethane, injected
Bearing	Precision ball bearing
Threadguards	With threadguard
Diameter	150 mm
Tread width	22 mm
Hardness of tread (A)	92 Shore A

HOUSING

Material fork	Polyamide
Fork shape	Twin wheel housing
Swivel bearing	Precision ball bearing
Colour	Silver grey (RAL7001)
Offset	52 mm
Swivel radius	133 mm
Swivel interference	218 mm
Dome diameter	56 mm

FITTING

Fitting type	Rectangular plate
Plate length	77 mm
Plate width	67 mm
Plate hole length (Minimum)	56 mm
Plate hole length (Maximum)	61.5 mm
Plate hole width (Minimum)	46.5 mm
Plate hole width (Maximum)	51.5 mm
Plate hole diameter	8.5 mm



Deutscher Designer Club



Interzum Award



IF Design Award

LINEA

5940UAP150P50 RAL7001

EAN 4031582411508



BETTER MOBILITY. BETTER LIFE.

TECHNICAL DRAWINGS

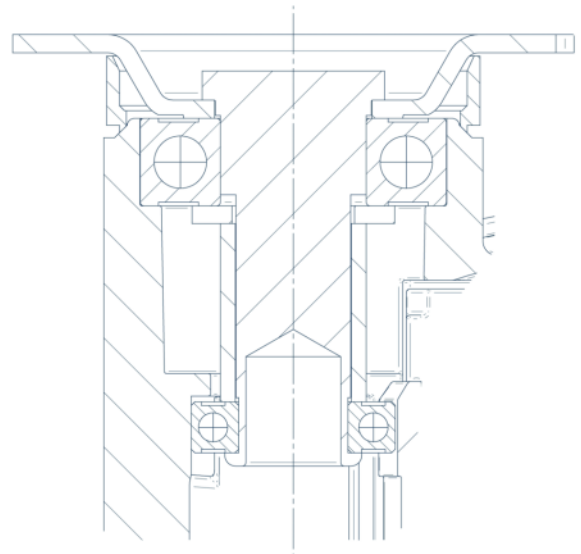
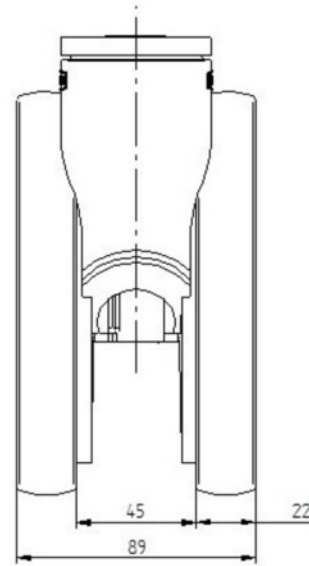
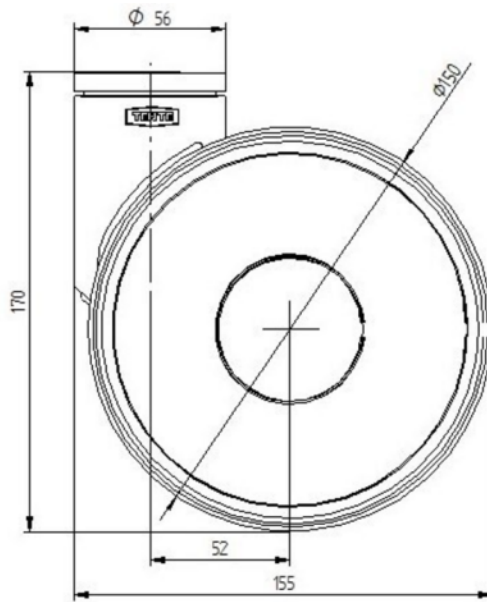

Deutscher
Designer
Club



Interzum
Award



IF
Design
Award