

PRODUCT INFORMATION

DURATECH

TOP 150x50-Ø20 HL60

EAN 4031582322699



BETTER MOBILITY. BETTER LIFE.



Image may differ from the original product

WHEEL

Body material	Polyamide, heavy
Tread material	Identical with wheel body
Bearing	Precision ball bearing
Wheel color	Natural white
Threadguards	Without threadguard
Diameter	5.91 in
Tread width	1.97 in
Axle hole diameter	0.79 in
Hub length	2.36 in
Body width	1.97 in
Hardness of tread (D)	75 Shore D
Bearing type	6204

PERFORMANCE

Roll Performance	●●●●●
Movement noise	●●○○○
Attrition	●●●●●
Corrosion resistance	●●●○○

CORE ATTRIBUTES

Product name	Duratech
Type	Wheel
Standard	EN12533 - Heavy Duty Castors
Load capacity at 2.5 mph	2116.44 lb
Load capacity at 3.7 mph	1763.7 lb
Electric conductive	no
Stainless	no
Load capacity Static	3527.39 lb
Temperature range (Minimum)	-40 °F
Temperature range (Maximum)	176 °F
Overall weight	2.2 lb

DURATECH

TOP 150x50-Ø20 HL60

EAN 4031582322699

Order number 00801045
Product Drawings



BETTER MOBILITY. BETTER LIFE.

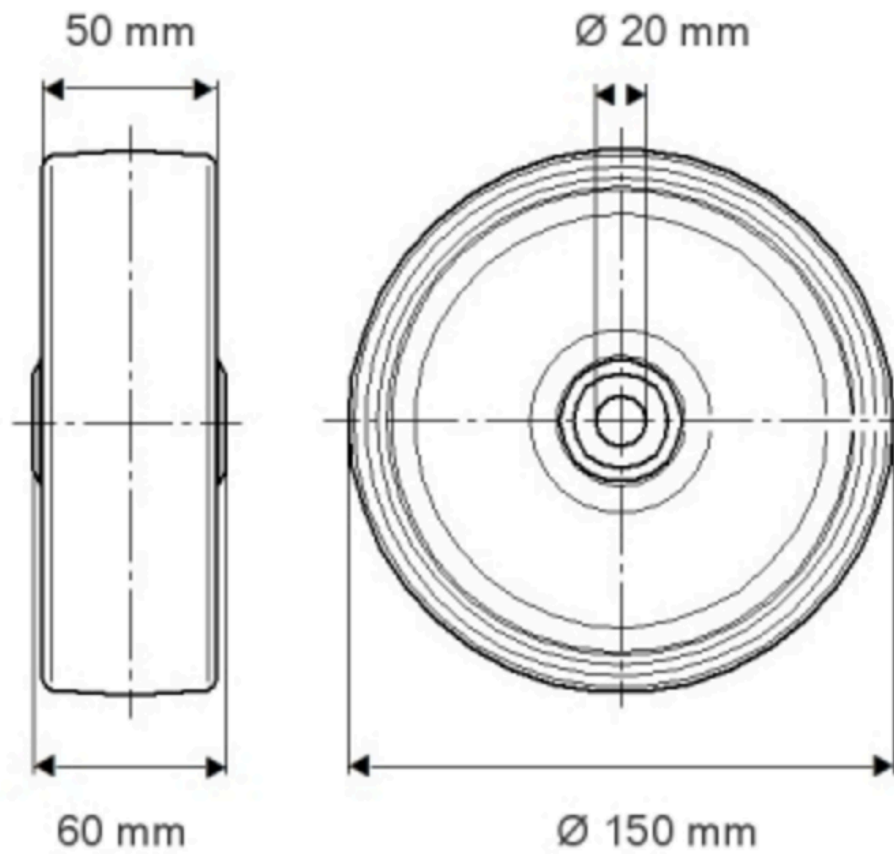

PRODUCT INFORMATION

DURATECH

TOP 150x50-Ø20 HL60

EAN 4031582322699

Order number 00801045



BETTER MOBILITY. BETTER LIFE.

