

INTEGRAL

2070PJP150R05-32

EAN 4031582348408



BETTER MOBILITY. BETTER LIFE.



Image may differ from the original product

PERFORMANCE

Roll performance	● ● ● ○ ○
Movement noise	● ● ● ○ ○
Attrition	● ● ● ○ ○
Corrosion resistance	● ● ● ○ ○

CORE ATTRIBUTES

Product name	Integral
Type	Swivel castor
Standard	EN12530 - Devices Castors
Load capacity at 1.8 mph	220.46 lb
Load capacity Static	440.92 lb
Temperature range (Minimum)	-4 °F
Temperature range (Maximum)	140 °F
Overall height	7.4 in
Certification	Tested and monitored by TÜV Süd

WHEEL

Body material	Polypropylene
Tread material	Thermoplastic rubber
Bearing	Precision ball bearing
Threadguards	Integrated threadguard
Diameter	5.91 in
Tread width	1.26 in
Hardness of tread (A)	87 Shore A

HOUSING

Material	Steel sheet, medium
Fork shape	Closed
Swivel bearing	Two ball races
Offset	1.77 in
Swivel radius	4.72 in
Swivel interference	9.45 in

FITTING

Fitting type	Solid stem, round
Bolt diameter	1.26 in
Bolt length	1.77 in



IF
Design
Award



Red Dot
Design
Award

INTEGRAL

2070PJP150R05-32

EAN 4031582348408



BETTER MOBILITY. BETTER LIFE.

TECHNICAL DRAWINGS

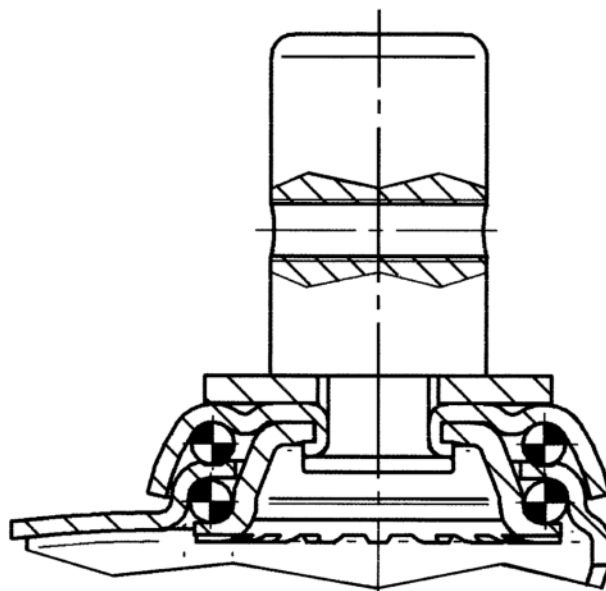

IF
Design
Award



Red Dot
Design
Award