

# INTEGRAL

2044UAX200R26-28S30 4XM8

EAN 4031582453652



BETTER MOBILITY. BETTER LIFE.



Image may differ from the original product

## PERFORMANCE

Roll performance	● ● ● ○ ○
Movement noise	● ● ● ○ ○
Attrition	● ● ● ● ○
Corrosion resistance	● ● ● ○ ○

## CORE ATTRIBUTES

Product name	Integral
Type	Swivel castor with central, total or directional lock
Standard	similar EN12531- Hospital Bed Castors
Load capacity at 1.8 mph	330.69 lb
Load capacity at 2.5 mph	330.69 lb
Load capacity Static	661.39 lb
Temperature range (Minimum)	-22 °F
Temperature range (Maximum)	176 °F
Overall height	9.02 in
Overall weight	3.69 lb
Certification	Tested and monitored by TÜV Süd

## WHEEL

Body material	Polyamide
Tread material	Polyurethane, injected
Bearing	Precision ball bearing, sealed
Threadguards	Integrated threadguard
Diameter	7.87 in
Tread width	1.38 in
Hardness of tread (D)	59 Shore D

## HOUSING

Material	Steel sheet, medium
Fork shape	Closed
Swivel bearing	Precision ball bearing
Offset	2.36 in
Swivel radius	6.3 in
Swivel interference	12.6 in

## FITTING

Fitting type	Stem with cam hole for profile bars
Bolt diameter	1.1 in
Bolt length	3.78 in
Hint	Washable beds must be sealed in the fitting area by the hospital bed manufacturer.



IF Design Award



Red Dot Design Award

# INTEGRAL

2044UAX200R26-28S30 4XM8

EAN 4031582453652



BETTER MOBILITY. BETTER LIFE.

## TECHNICAL DRAWINGS

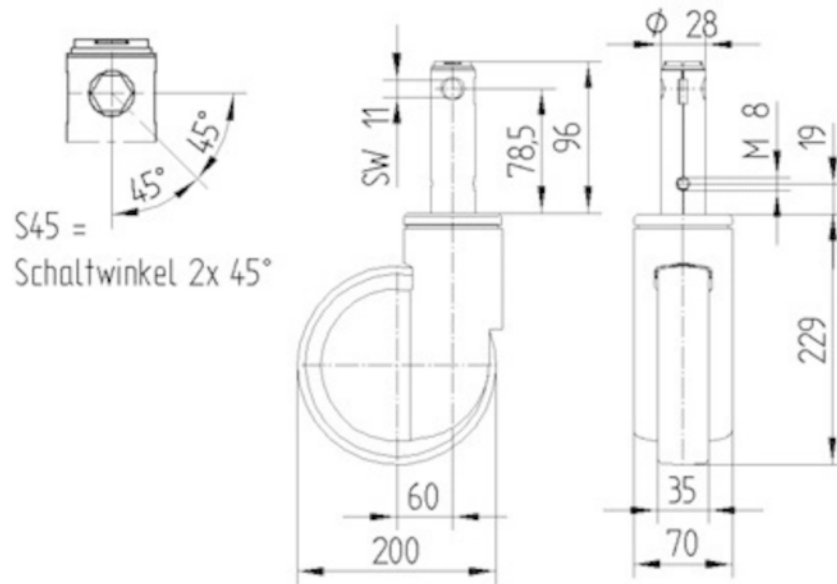

IF  
Design  
Award



Red Dot  
Design  
Award