

LEVINA

5371XSP125P30-13 WINDOW-GREY/6032

EAN 4031582359398
Order number 00063893



BETTER MOBILITY. BETTER LIFE.



Image may differ from the original product

PERFORMANCE

| | |
|----------------------|-------|
| Roll performance | ●●●○○ |
| Movement noise | ●●●○○ |
| Attrition | ●●●●○ |
| Corrosion resistance | ●●●●○ |

CORE ATTRIBUTES

| | |
|-----------------------------|-------------------------------------|
| Product name | Levina |
| Type | Swivel castor with directional lock |
| Standard | EN12530 - Devices Castors |
| Load capacity at 3 km/h | 100 kg |
| Electric conductive | ✓ |
| Load capacity Static | 200 kg |
| Temperature range (Minimum) | -10 °C |
| Temperature range (Maximum) | 40 °C |
| Overall height | 161 mm |
| Overall width | 59 mm |
| Overall weight | 0.641 kg |

WHEEL

| | |
|-----------------------|---|
| Body material | Polyamide, electric conductive |
| Tread material | Polyurethane, injected, electric-conductive |
| Bearing | Precision ball bearing |
| Wheel color | Silver grey (RAL7001) |
| Threadguards | With threadguard |
| Diameter | 125 mm |
| Tread width | 32 mm |
| Body width | 32 mm |
| Hardness of tread (A) | 91 Shore A |
| Hardness of tread (D) | 40 Shore D |

HOUSING

| | |
|---------------------|-------------------------------|
| Material fork | Polyamide |
| Fork shape | Slim |
| Swivel bearing | Two ball races |
| Colour | Window grey (similar RAL7040) |
| Offset | 38 mm |
| Swivel radius | 100.5 mm |
| Swivel interference | 201 mm |
| Dome diameter | 59 mm |

FITTING

| | |
|--------------------|-----------|
| Fitting type | Bolt hole |
| Bolt hole diameter | 13 mm |



Universal Design Award



Deutscher Designer Club

LEVINA

5371XSP125P30-13 WINDOW-GREY/6032

EAN 4031582359398
Order number 00063893



BETTER MOBILITY. BETTER LIFE.

TECHNICAL DRAWINGS

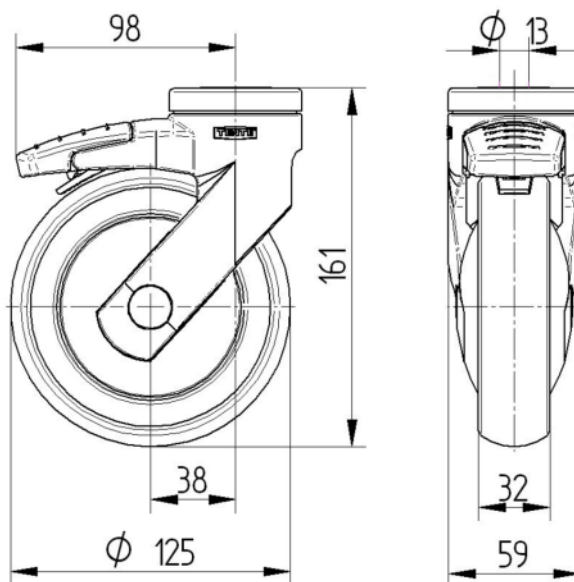

Universal
Design
Award



Deutscher
Designer
Club