

# LEVINA

5377XSP100P51

EAN 4031582359336



BETTER MOBILITY. BETTER LIFE.



Image may differ from the original product

## PERFORMANCE

Roll performance	●●●○○
Movement noise	●●●●○
Attrition	●●●●○
Corrosion resistance	●●●●○

## CORE ATTRIBUTES

Product name	Levina
Type	Swivel castor with total lock
Standard	EN12530 - Devices Castors
Load capacity at 3 km/h	100 kg
Electric conductive	✓
Load capacity Static	200 kg
Temperature range (Minimum)	-10 °C
Temperature range (Maximum)	40 °C
Overall height	141 mm

## WHEEL

Body material	Polyamide, electric conductive
Tread material	Polyurethane, injected, electric-conductive
Bearing	Precision ball bearing
Threadguards	With threadguard
Diameter	100 mm
Tread width	32 mm
Hardness of tread (D)	40 Shore D

## HOUSING

Material fork	Polyamide
Fork shape	Slim
Swivel bearing	Two ball races
Offset	36 mm
Swivel radius	98 mm
Swivel interference	196 mm

## FITTING

Fitting type	Rectangular plate
Plate length	95 mm
Plate width	70 mm
Plate hole length (Maximum)	75 mm
Plate hole width (Maximum)	50 mm
Plate hole diameter	11 mm



Universal Design Award



Deutscher Designer Club

# LEVINA

5377XSP100P51

EAN 4031582359336



BETTER MOBILITY. BETTER LIFE.

## TECHNICAL DRAWINGS

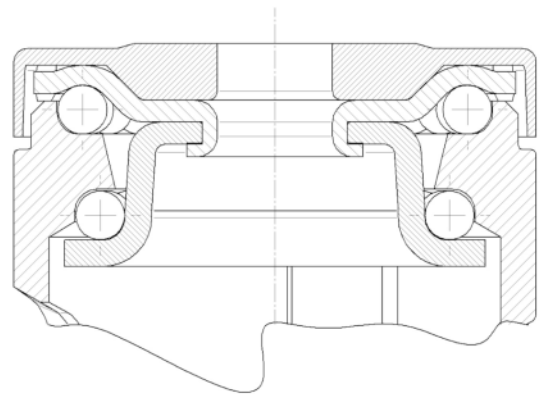
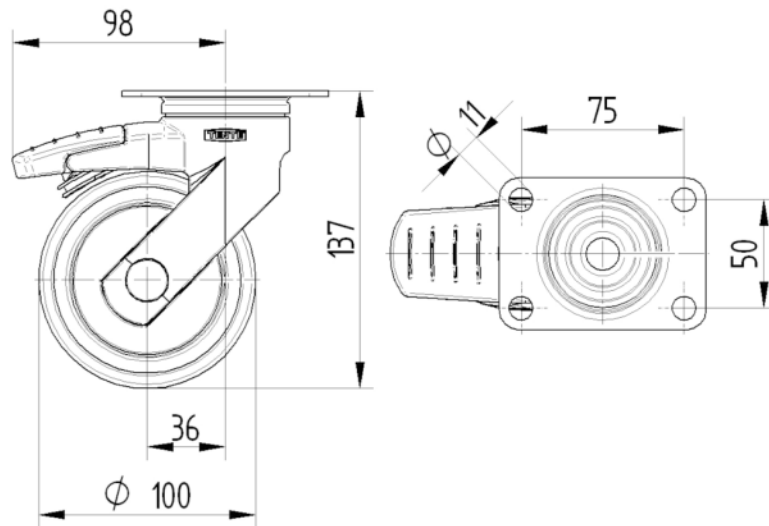

Universal  
Design  
Award



Deutscher  
Designer  
Club