

# LINEA

5941UAP100R05-28 RAL9002

EAN 4031582368741



BETTER MOBILITY. BETTER LIFE.



Afbeelding kan verschillen van het oorspronkelijke product

## PRESTATIES

Rolprestaties	● ● ● ● ●
Bewegingsgeluid	● ● ● ○ ○
Verloop	● ● ● ● ○
Corrosieweerstand	● ● ● ● ○

## KERNKENMERKEN

Productnaam	Linea
Type	Zwenkwiel met richtingsvastzetter
Standaard	EN12530 - Apparaten zwenkwielen
Draagvermogen bij 3 km/u	120 kg
Statisch Draagvermogen	240 kg
Temperatuurbereik (minimaal)	-10 °C
Temperatuurbereik (maximaal)	40 °C
Totale hoogte	120 mm
Totale breedte	82 mm
Totaal gewicht	0,93 kg

## WIEL

Wielkern materiaal	Polyamide
Materiaal loopvlak	Polyurethaan, Gespoten
Lager	Precisie kogellagers
Afdekkapjes	Met afdekkapjes
Diameter	100 mm
Breedte Loopvlak	20 mm
Hardheid van het loopvlak (A)	92 Shore A

## VORK

Materiaal	Polyamide
Vork Vorm	Dubbele vorkwiel
Zwenklager	Precisie kogellagers
Kleur	Grijs wit (RAL9002)
Offset	32 mm
Zwenk radius	108 mm
Uitzwenking	216 mm
Diameter koepel	52 mm

## BEVESTIGING

Type bevestiging	Vaste Stift, rond
Diameter Bout	28 mm
Lengte Bout	40 mm



Duitse  
OntwerpersClub



Interzum  
Award



IF  
Design  
Award

# LINEA

5941UAP100R05-28 RAL9002

EAN 4031582368741



BETTER MOBILITY. BETTER LIFE.

## TECHNISCHE TEKENINGEN

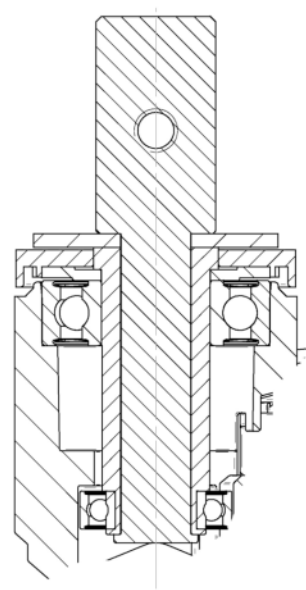
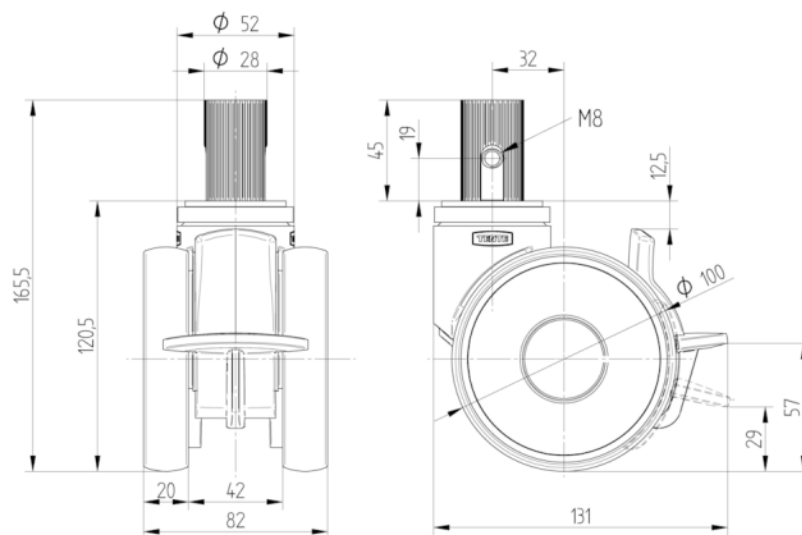

Duitse  
OntwerpersClub



Interzum  
Award



IF  
Design  
Award