

# LINEA LOAD

5940UAP050L51-8 LOAD 9011

EAN 4031582431100



BETTER MOBILITY. BETTER LIFE.



Image may differ from the original product

## PERFORMANCE

Roll performance	● ● ● ● ●
Movement noise	● ● ● ● ○
Attrition	● ● ● ● ●
Corrosion resistance	● ● ● ● ○

## CORE ATTRIBUTES

Product name	Linea load
Type	Swivel castor
Standard	EN12530 - Devices Castors
Load capacity at 1.8 mph	220.46 lb
Load capacity Static	440.92 lb
Temperature range (Minimum)	14 °F
Temperature range (Maximum)	104 °F
Overall height	1.99 in
Overall width	1.87 in
Overall weight	0.19 lb

## WHEEL

Body material	Polyamide
Tread material	Polyurethane, injected
Bearing	Precision ball bearing
Threadguards	With threadguard
Diameter	1.97 in
Tread width	0.51 in
Hardness of tread (A)	92 Shore A

## HOUSING

Material	Polyamide
Fork shape	Twin wheel housing
Swivel bearing	Precision ball bearing
Color	Graphite black (RAL9011)
Swivel radius	1.59 in
Swivel interference	3.19 in
Dome diameter	0.91 in

## FITTING

Fitting type	Blind hole for B10 fitting
Bolt hole diameter	0.31 in



# LINEA LOAD

5940UAP050L51-8 LOAD 9011

EAN 4031582431100



BETTER MOBILITY. BETTER LIFE.

## TECHNICAL DRAWINGS

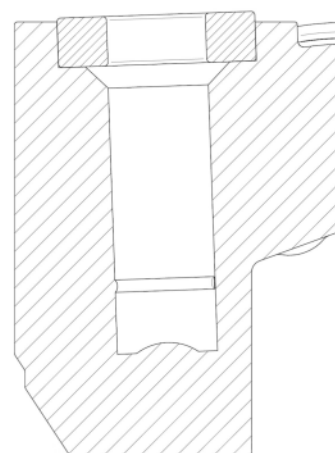
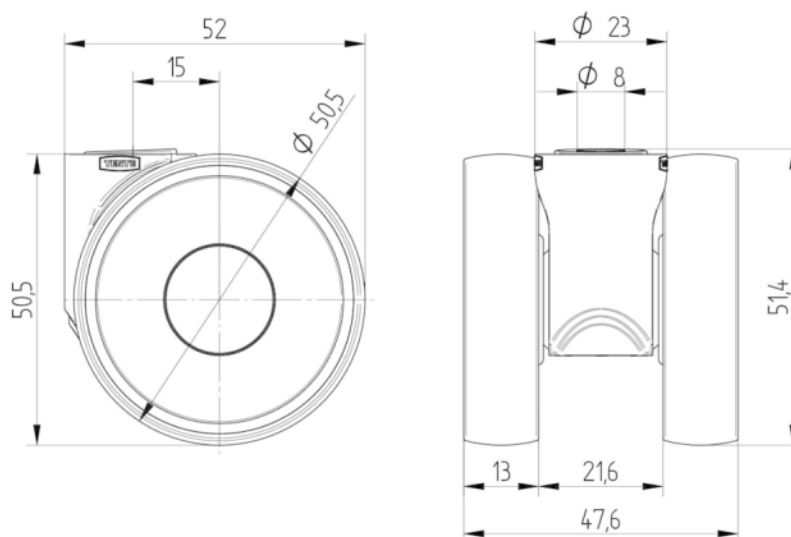

Deutscher  
Designer  
Club



Interzum  
Award



IF  
Design  
Award