

# LINEA

5940UAP125R05-22 RAL7001

EAN 4031582350715  
Order number 00770132



BETTER MOBILITY. BETTER LIFE.



Image may differ from the original product

## PERFORMANCE

Roll performance	● ● ● ● ●
Movement noise	● ● ● ○ ○
Attrition	● ● ● ● ○
Corrosion resistance	● ● ● ● ○

## CORE ATTRIBUTES

Product name	Linea
Type	Swivel castor
Standard	EN12530 - Devices Castors
Load capacity at 1.8 mph	242.51 lb
Load capacity Static	485.02 lb
Temperature range (Minimum)	-4 °F
Temperature range (Maximum)	140 °F
Overall height	5.63 in
Overall width	3.23 in
Overall weight	2.07 lb

## WHEEL

Body material	Polyamide
Tread material	Polyurethane, injected
Bearing	Precision ball bearing
Tread color	Slate gray (RAL7015)
Wheel color	Slate gray (RAL7015)
Threadguards	With threadguard
Diameter	4.92 in
Tread width	0.79 in
Body width	0.79 in
Hardness of tread (A)	92 Shore A

## HOUSING

Material	Polyamide
Fork shape	Twin wheel housing
Swivel bearing	Precision ball bearing
Color	Silver gray (RAL7001)
Offset	1.57 in
Swivel radius	4.29 in
Swivel interference	8.58 in
Dome diameter	2.05 in

## FITTING

Fitting type	Solid stem, round
Bolt diameter	0.87 in
Bolt length	1.57 in



Deutscher  
Designer  
Club



Interzum  
Award



IF  
Design  
Award

# LINEA

5940UAP125R05-22 RAL7001

EAN 4031582350715  
Order number 00770132



BETTER MOBILITY. BETTER LIFE.

## TECHNICAL DRAWINGS

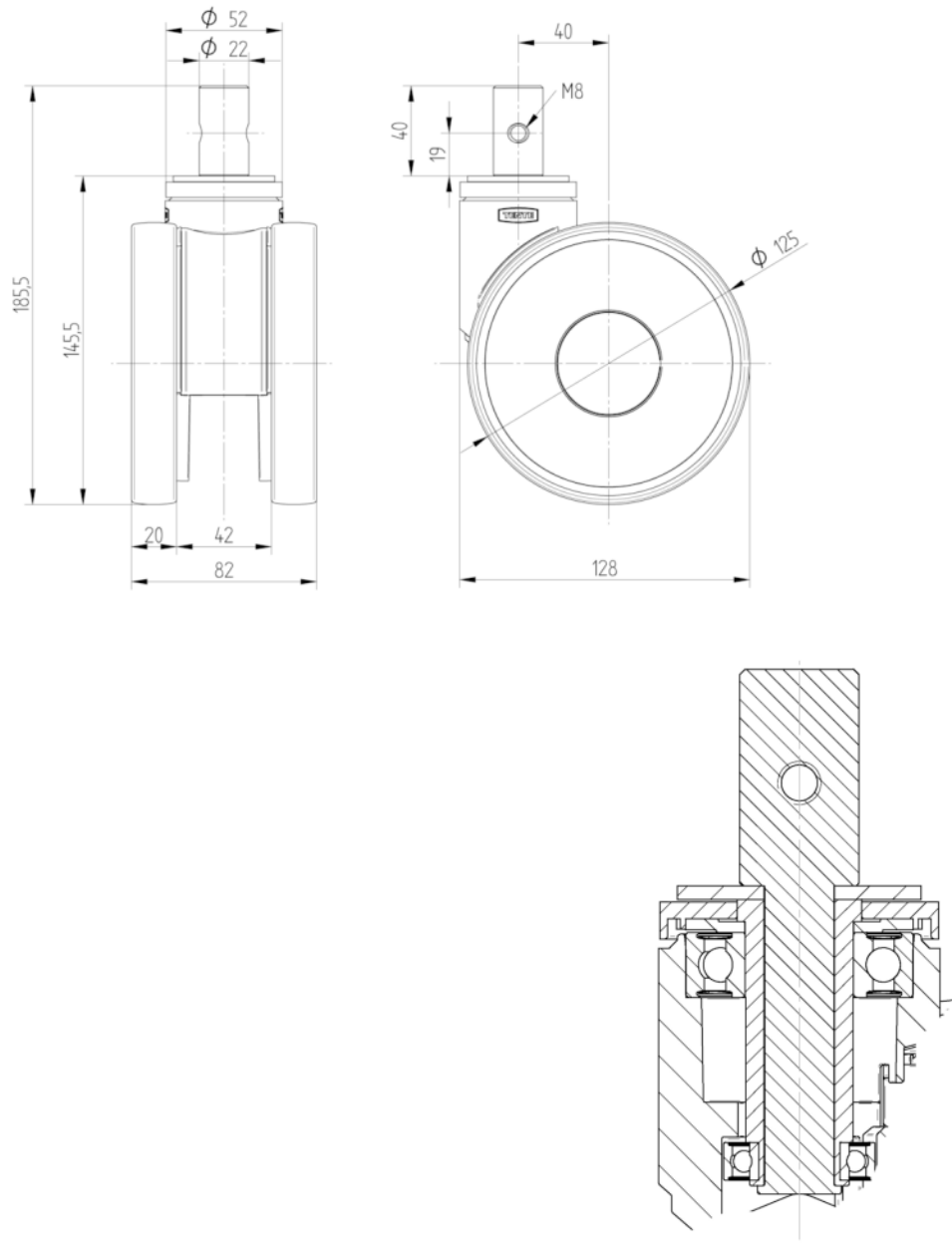

Deutscher  
Designer  
Club



Interzum  
Award



IF  
Design  
Award