

LINEA SAFETY

592DUAP075L51-10 RAL9002

EAN 4031582358252



BETTER MOBILITY. BETTER LIFE.



Afbeelding kan verschillen van het oorspronkelijke product

PRESTATIES

Rolprestaties	● ● ● ○ ○
Bewegingsgeluid	● ● ● ○ ○
Verloop	● ● ● ○ ○
Corrosieweerstand	● ● ● ● ○

KERNKENMERKEN

Productnaam	Linea safety
Type	Automatisch remsysteem
Standaard	EN12528 - Meubelwielen
Draagvermogen bij 3 km/u	100 kg
Statisch Draagvermogen	200 kg
Temperatuurbereik (minimaal)	-20 °C
Temperatuurbereik (maximaal)	60 °C
Totale hoogte	75,5 mm
Totale breedte	55 mm
Totaal gewicht	0,179 kg

WIEL

Wielkern materiaal	Polyamide
Materiaal loopvlak	Polyurethaan, Gespoten
Lager	Precisie kogellagers
Afdekkapjes	Met afdekkapjes
Diameter	75 mm
Breedte Loopvlak	15 mm

VORK

Materiaal	Polyamide
Vork Vorm	Dubbele vorkwiel
Zwenklager	Stift, zwenkend
Kleur	Grijs wit (RAL9002)
Offset	23 mm
Zwenk radius	66 mm
Uitzwenking	132 mm
Diameter koepel	30 mm
Tip	Kracht om 23 N en veer slaglengte 8 mm vrij te geven.

BEVESTIGING

Type bevestiging	Stiftgat voor B10-bevestiging
Diameter boutgat diameter	10 mm

Duitse
OntwerpersClubInterzum
AwardIF
Design
Award

LINEA SAFETY

592DUAP075L51-10 RAL9002

EAN 4031582358252



BETTER MOBILITY. BETTER LIFE.

TECHNISCHE TEKENINGEN

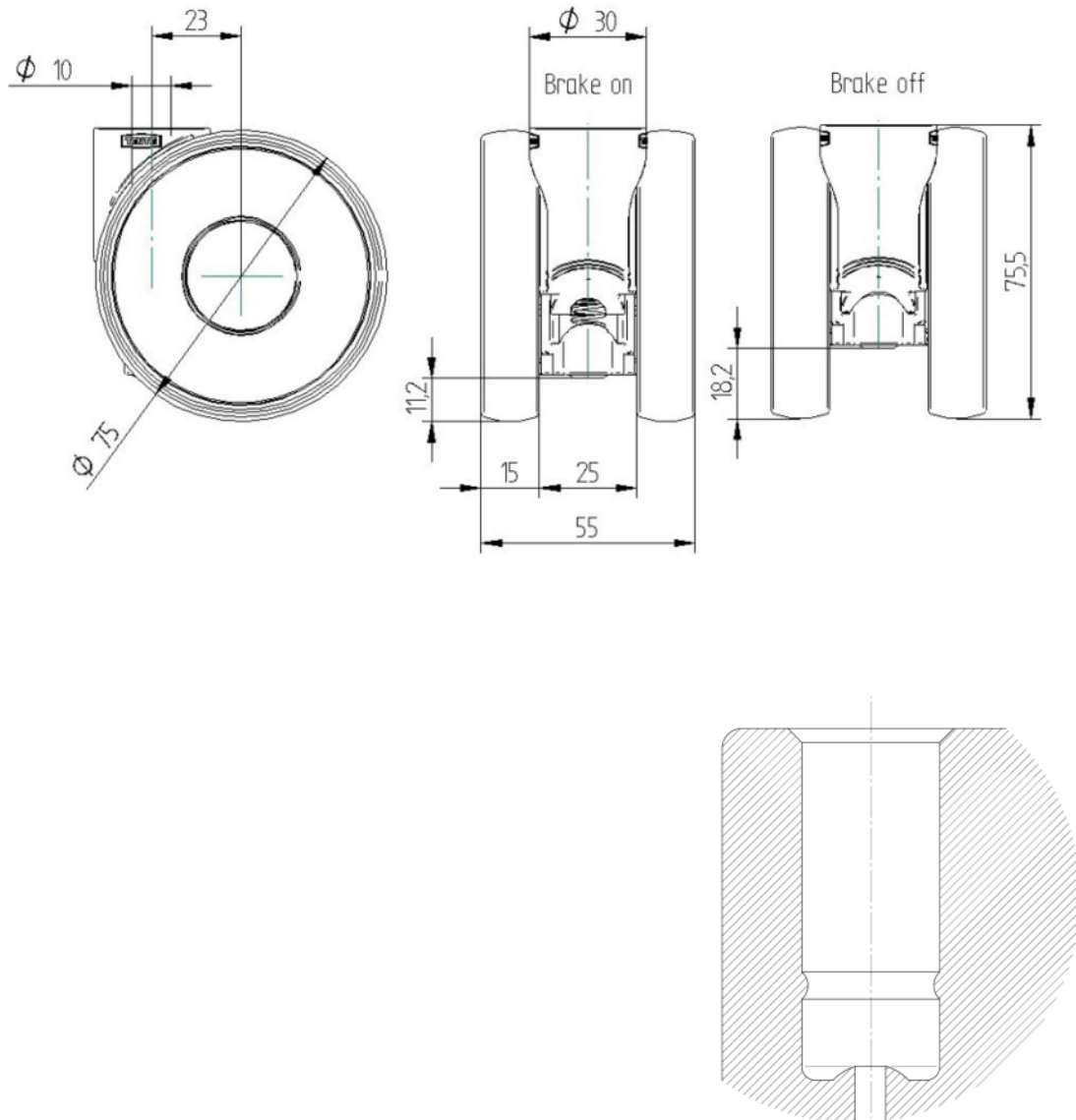

Duitse
OntwerpersClub



Interzum
Award



IF
Design
Award