

# NOVATECH

FTP250x80-Ø35 HL90 TFR

EAN 4031582389548



BETTER MOBILITY. BETTER LIFE.



Image may differ from the original product

## WHEEL

Body material	Cast iron
Tread Material Mix	Polyurethane, casted
Bearing	Precision ball bearing
Threadguards	With threadguard
Diameter	250 mm
Tread width	80 mm
Axle Hole Diameter	35 mm
Hub Length	90 mm
Hardness of tread (A)	92 Shore A

## PERFORMANCE

Roll Performance	● ● ● ● ● ○
Movement Noise	● ● ● ● ○ ○
Attrition	● ● ● ● ● ○
Corrosion Resistance	● ● ● ● ○ ○

## CORE ATTRIBUTES

Product Name	Novatech
Type	Wheel
Standard	EN12533 - Heavy Duty Castors
Load capacity at 4 km/h	2160 kg
Load capacity at 6 km/h	1800 kg
Electric Conductive	No
Stainless	No
Load capacity Static	4320 kg
Temperature range (Minimum)	-20 °C
Temperature range (Maximum)	60 °C
Overall weight	11.91 kg

# NOVATECH

FTP250x80-Ø35 HL90 TFR

EAN 4031582389548



BETTER MOBILITY. BETTER LIFE.

## Product Drawings

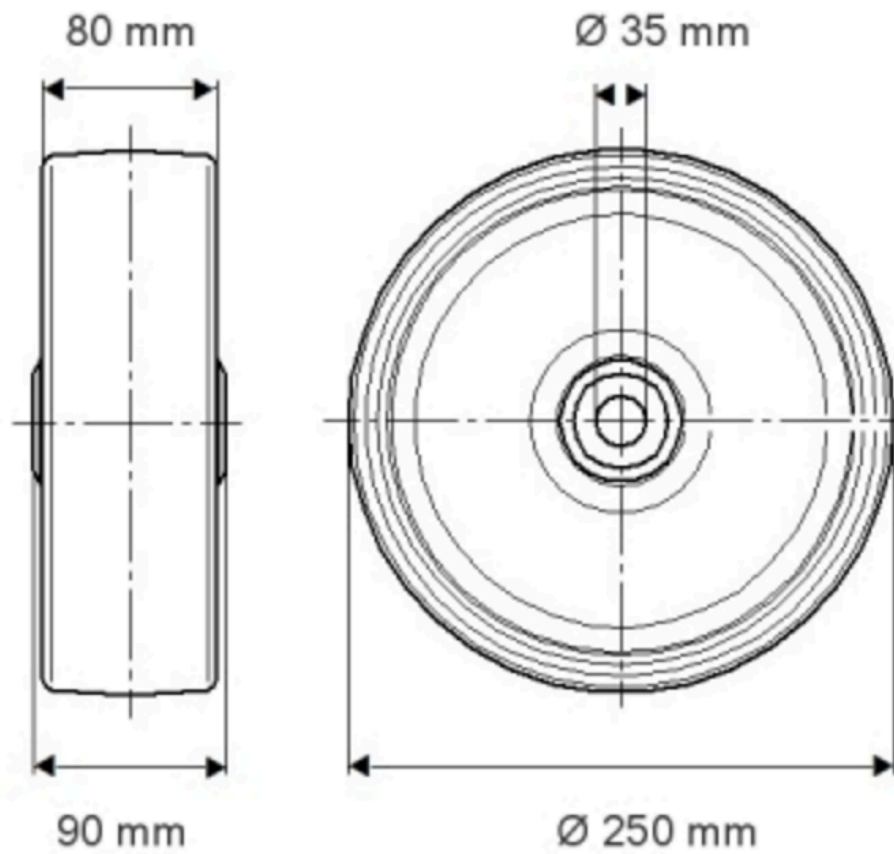

PRODUCT INFORMATION

# NOVATECH

FTP250x80-ØB5 HL90 TFR

EAN 4031582389548

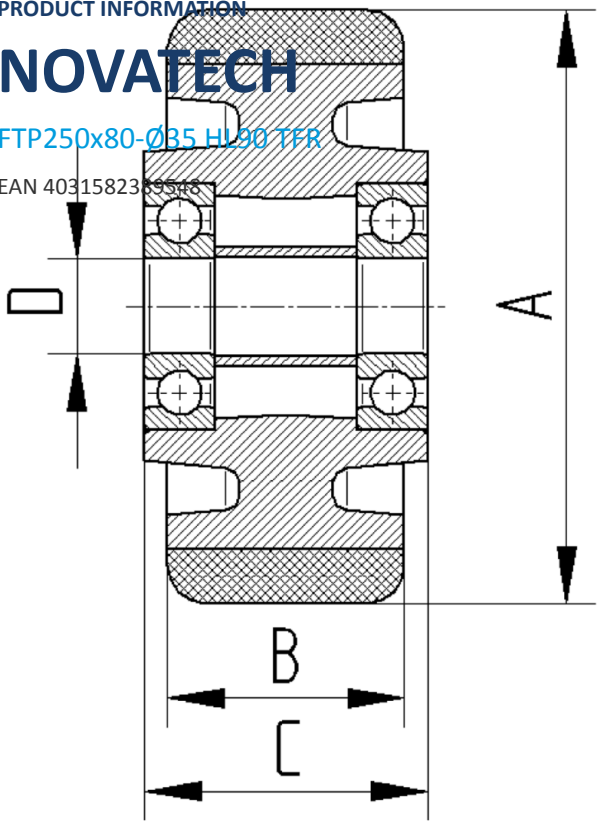

BETTER MOBILITY. BETTER LIFE.