

NOVATECH

FTP 300x100-Ø40 HL120

EAN 4031582319439



BETTER MOBILITY. BETTER LIFE.



Image may differ from the original product

WHEEL

Body material	Cast iron
Tread Material Mix	Polyurethane, casted
Bearing	Precision ball bearing
Wheel Color	Honey yellow (RAL1005)
Threadguards	With threadguard
Diameter	300 mm
Tread width	100 mm
Axle Hole Diameter	40 mm
Hub Length	120 mm
Body width	100 mm
Hardness of tread (A)	92 Shore A
Hardness of tread (D)	42 Shore D

PERFORMANCE

Roll Performance	● ● ● ● ● ○
Movement Noise	● ● ● ● ○ ○
Attrition	● ● ● ● ● ○
Corrosion Resistance	● ● ● ● ○ ○

CORE ATTRIBUTES

Product Name	Novatech
Type	Wheel
Standard	EN12533 - Heavy Duty Castors
Load capacity at 4 km/h	3120 kg
Load capacity at 6 km/h	2600 kg
Electric Conductive	No
Stainless	No
Load capacity Static	5200 kg
Temperature range (Minimum)	-10 °C
Temperature range (Maximum)	60 °C
Overall weight	18.81 kg

NOVATECH

FTP 300x100-Ø40 HL120

EAN 4031582319439

Order number 00801175
Product Drawings



BETTER MOBILITY. BETTER LIFE.

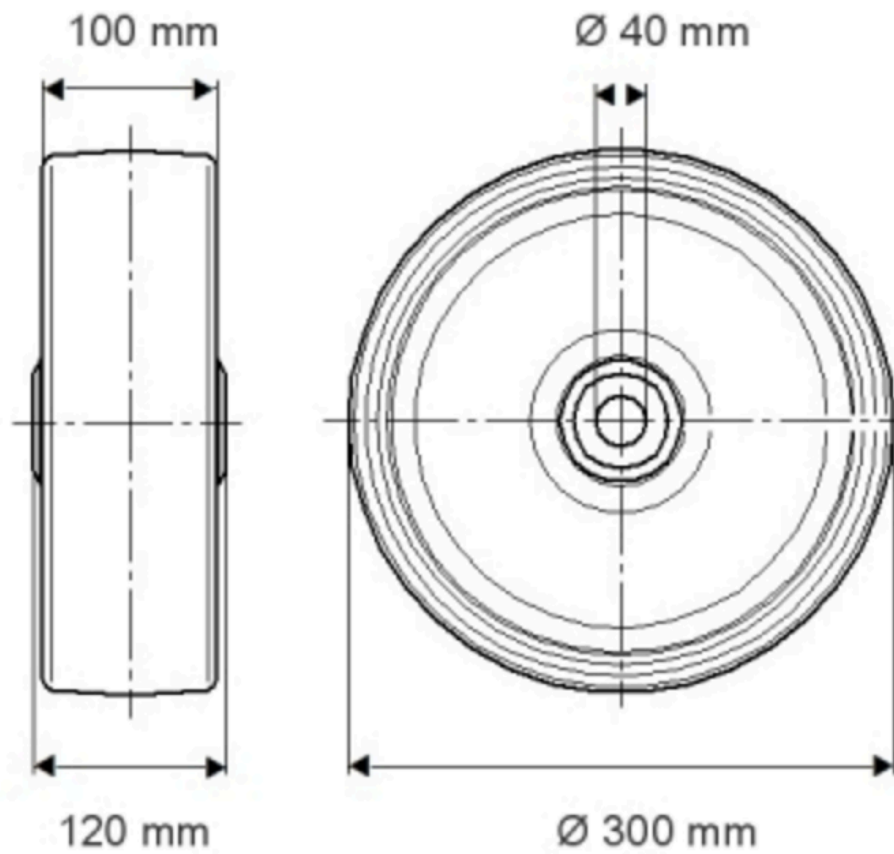

PRODUCT INFORMATION

NOVATECH

FTP 300x100-Ø40 H1.120

EAN 4031582319439

Order number 00801175

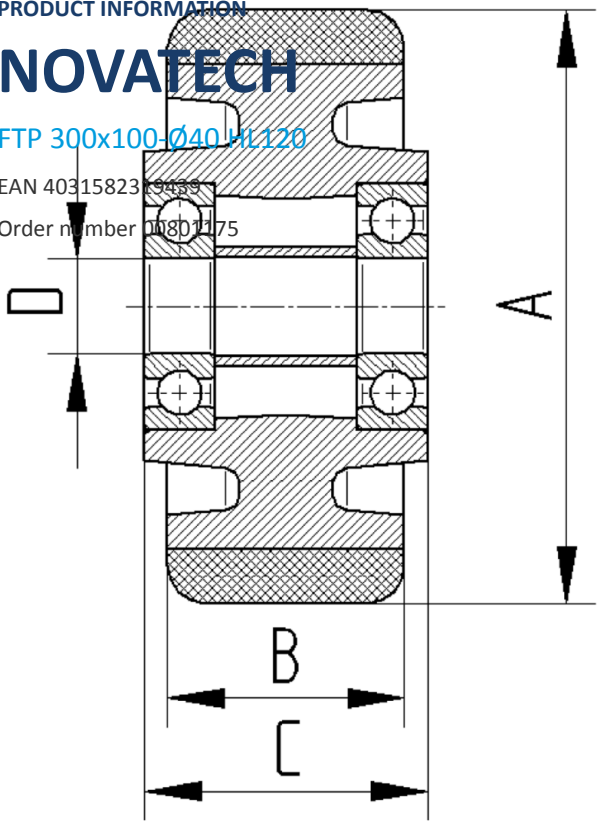

BETTER MOBILITY. BETTER LIFE.