

LINEA

594CUAP150P30-13 RAL7001

EAN 4031582411409



BETTER MOBILITY. BETTER LIFE.



Afbeelding kan verschillen van het oorspronkelijke product

PRESTATIES

Rolprestaties	● ● ● ● ●
Bewegingsgeluid	● ● ● ● ○
Verloop	● ● ● ● ○
Corrosieweerstand	● ● ● ● ○

KERNKENMERKEN

Productnaam	Linea
Type	Zwenkwiel met gecombineerde rem
Standaard	EN12530 - Apparaten zwenkwielen
Draagvermogen bij 3 km/u	130 kg
Statisch Draagvermogen	260 kg
Temperatuurbereik (minimaal)	-20 °C
Temperatuurbereik (maximaal)	60 °C
Totale hoogte	170 mm
Totale breedte	89 mm
Totaal gewicht	1,3 kg
Certificering	Getest en gecontroleerd door TÜV Süd

WIEL

Wielkern materiaal	Polyamide
Materiaal loopvlak	Polyurethaan, Gespoten
Lager	Precisie kogellagers
Afdekkapjes	Met afdekkapjes
Diameter	150 mm
Breedte Loopvlak	22 mm
Hardheid van het loopvlak (A)	92 Shore A

VORK

Materiaal	Polyamide
Vork Vorm	Dubbele vorkwiel
Zwenklager	Precisie kogellagers
Kleur	Zilvergrijs (RAL7001)
Offset	52 mm
Zwenk radius	156 mm
Uitzwenking	312 mm
Diameter koepel	56 mm

BEVESTIGING

Type bevestiging	Boutgat
Diameter boutgat diameter	13 mm



Duitse OntwerpersClub



Interzum Award



IF Design Award

LINEA

594CUAP150P30-13 RAL7001

EAN 4031582411409



BETTER MOBILITY. BETTER LIFE.

TECHNISCHE TEKENINGEN

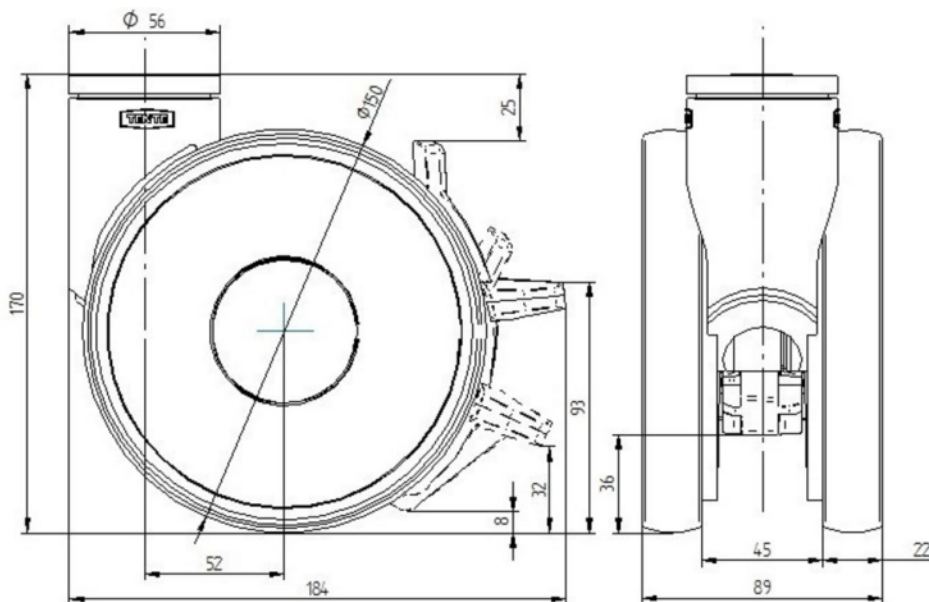

Duitse
OntwerpersClub



Interzum
Award



IF
Design
Award