

NOVATECH

FTP 125x50-Ø20 HL60

EAN 4031582329407



BETTER MOBILITY. BETTER LIFE.



Image may differ from the original product

WHEEL

Body material	Cast iron
Tread Material Mix	Polyurethane, casted
Bearing	Precision ball bearing
Wheel Color	Honey yellow (RAL1005)
Threadguards	With threadguard
Diameter	125 mm
Tread width	50 mm
Axle Hole Diameter	20 mm
Hub Length	60 mm
Body width	50 mm
Hardness of tread (A)	92 Shore A
Hardness of tread (D)	42 Shore D
Bearing type	6204
Suitable for	bt

PERFORMANCE

Roll Performance	●●●●○
Movement Noise	●●●○○
Attrition	●●●●○
Corrosion Resistance	●●●○○

CORE ATTRIBUTES

Product Name	Novatech
Type	Wheel
Standard	EN12533 - Heavy Duty Castors
Load capacity at 4 km/h	660 kg
Load capacity at 6 km/h	550 kg
Electric Conductive	No
Stainless	No
Load capacity Static	1100 kg
Temperature range (Minimum)	-10 °C
Temperature range (Maximum)	60 °C
Overall weight	2.43 kg

NOVATECH

FTP 125x50-Ø20 HL60

EAN 4031582329407

Order number 00800994
Product Drawings



BETTER MOBILITY. BETTER LIFE.

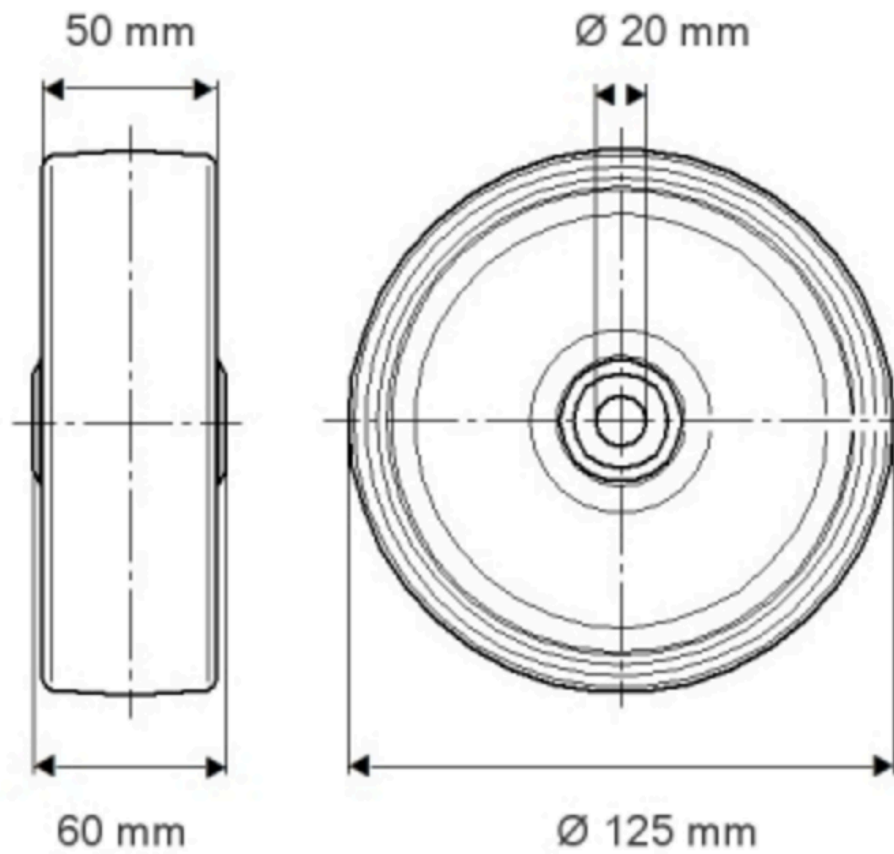

PRODUCT INFORMATION

NOVATECH

FTP 125x50-020 H160

EAN 4031582329407

Order number 00800994

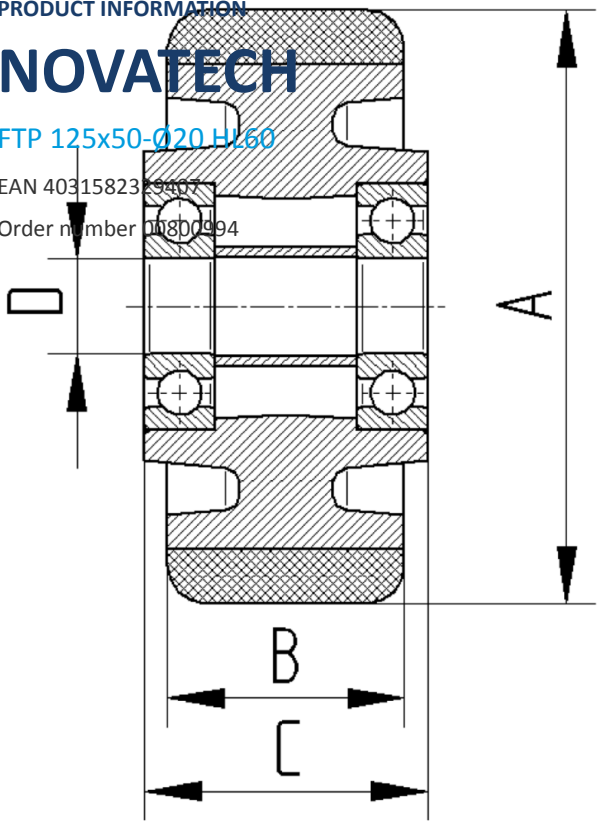

BETTER MOBILITY. BETTER LIFE.