

# LINEA SAFETY

592DUAP100L51-11 RAL9002

EAN 4031582415353



BETTER MOBILITY. BETTER LIFE.



Image may differ from the original product

## PERFORMANCE

Roll Performance	● ● ● ● ○ ○
Movement Noise	● ● ● ● ○ ○
Attrition	● ● ● ● ○ ○
Corrosion Resistance	● ● ● ● ○ ○

## CORE ATTRIBUTES

Product Name	Linea safety
Type	Automatic locking system
Standard	EN12528 - Furniture Castors
Load capacity at 3 km/h	100 kg
Electric Conductive	No
Stainless	No
Load capacity Static	200 kg
Temperature range (Minimum)	-20 °C
Temperature range (Maximum)	60 °C
Overall Height	100 mm
Overall width	73 mm

## HOUSING

Housing Material	Polyamide
Fork shape	Twin wheel housing
Swivel Bearing	Stem, swiveling
Housing Color	Grey white (RAL9002)
Swivel radius	88 mm
Swivel interference	176 mm
Dome diameter	40 mm

## WHEEL

Body material	Polyamide
Tread Material Mix	Polyurethane, injected
Bearing	Precision ball bearing
Threadguards	With threadguard
Diameter	100 mm
Tread width	20 mm

## FITTING

Fitting type	Blind hole for B10
Bolt hole diameter	11 mm



Deutscher Designer Club



Interzum Award



product design award

IF Design Award

# LINEA SAFETY

592DUAP100L51-11 RAL9002

EAN 4031582415353



BETTER MOBILITY. BETTER LIFE.

## Product Drawings

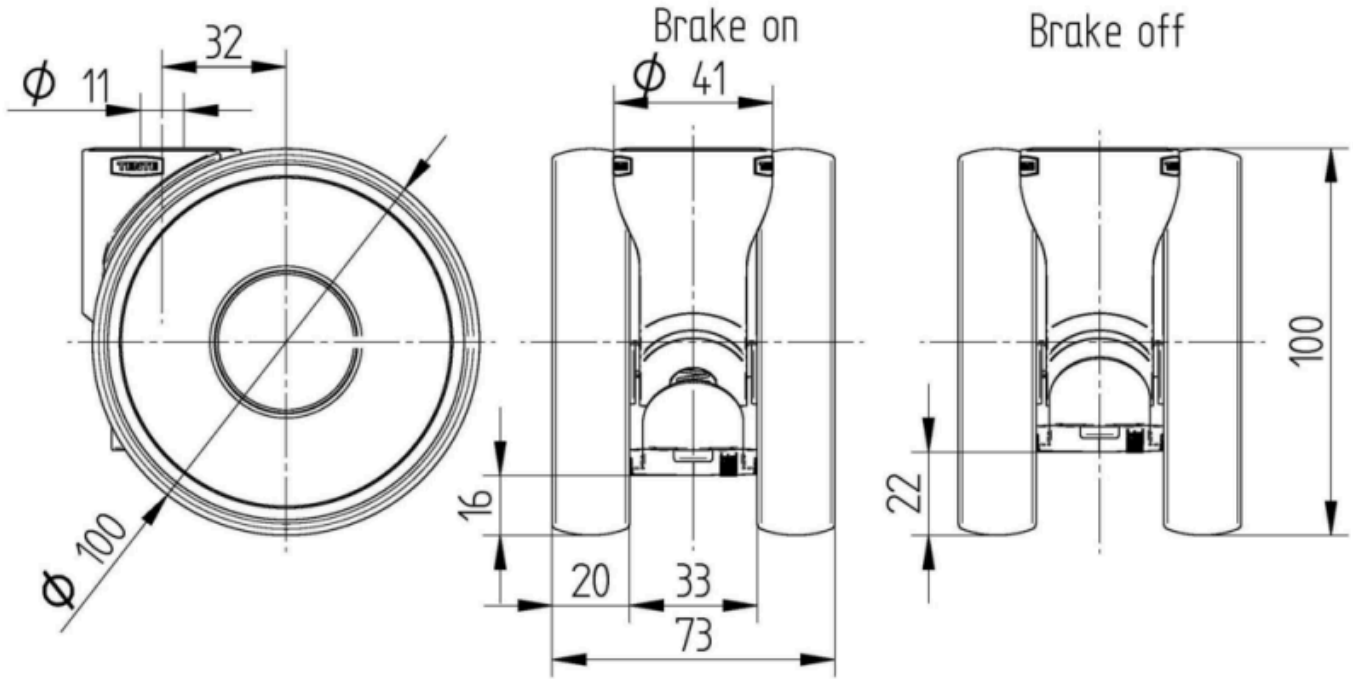

Deutscher  
Designer  
Club



Interzum  
Award



product  
design  
award

IF Design  
Award