

PRODUCT INFORMATION

PURETECH

FVP 300x85-Ø30 HL90

EAN 4031582319538



BETTER MOBILITY. BETTER LIFE.



Image may differ from the original product

WHEEL

Tread hardness	soft
Body material	Casting
Tread material	Solid rubber, black
Bearing	Precision ball bearing
Wheel color	Jet black (similar RAL9005)
Threadguards	With threadguard
Diameter	11.81 in
Tread width	3.35 in
Axle hole diameter	1.18 in
Hub length	3.54 in
Body width	3.35 in
Hardness of tread (A)	67 Shore A

PERFORMANCE

Roll Performance	● ● ● ○ ○ ○
Movement noise	● ● ● ● ●
Attrition	● ● ● ● ○ ○
Corrosion resistance	● ● ● ○ ○

CORE ATTRIBUTES

Product name	Puretech
Type	Wheel
Standard	EN12533 - Heavy Duty Castors
Load capacity at 2.5 mph	2116.44 lb
Load capacity at 3.7 mph	1763.7 lb
Electric conductive	no
Stainless	no
Load capacity Static	3527.39 lb
Temperature range (Minimum)	-4 °F
Temperature range (Maximum)	176 °F
Overall weight	21.61 lb

PURETECH

FVP 300x85-Ø30 HL90

EAN 4031582319538

Order number 00801896
Product Drawings



BETTER MOBILITY. BETTER LIFE.

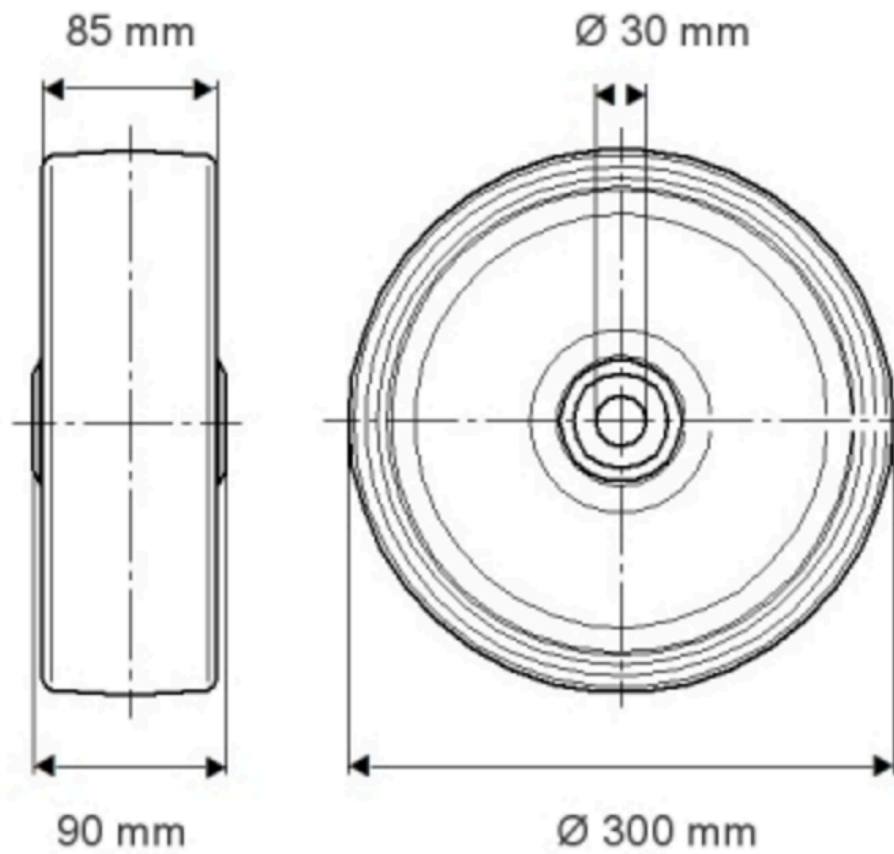

PRODUCT INFORMATION

PURETECH

FVP 300x85-Ø30 H190

EAN 4031582319538

Order number 01801896

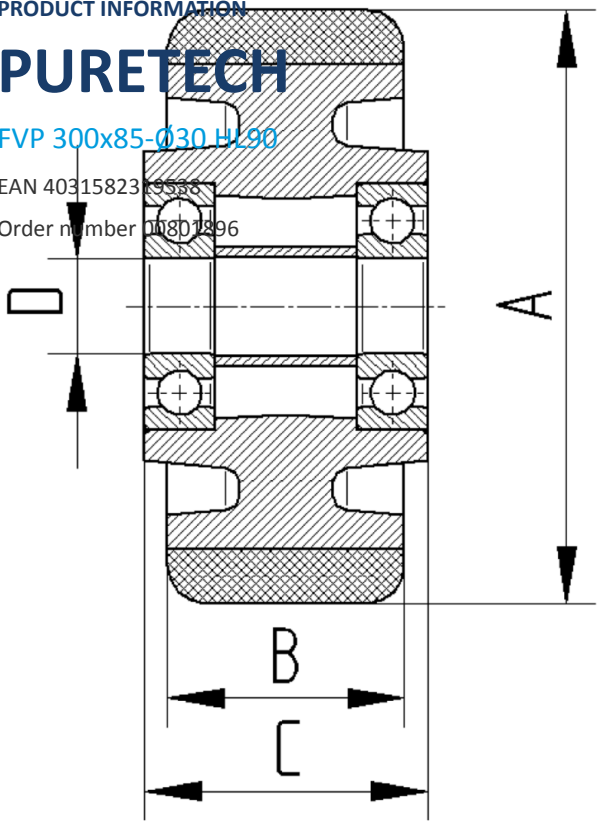

BETTER MOBILITY. BETTER LIFE.