

LINEA SAFETY

592DUAP100L51-11 RAL9002

EAN 4031582415353



BETTER MOBILITY. BETTER LIFE.



Image may differ from the original product

PERFORMANCE

Roll Performance	● ● ● ● ○ ○
Movement noise	● ● ● ● ○ ○
Attrition	● ● ● ● ○ ○
Corrosion resistance	● ● ● ● ○ ○

CORE ATTRIBUTES

Product name	Linea safety
Type	Automatic locking system
Standard	EN12528 - Furniture Castors
Load capacity at 1.8 mph	220.46 lb
Electric conductive	no
Stainless	no
Load capacity Static	440.92 lb
Temperature range (Minimum)	-4 °F
Temperature range (Maximum)	140 °F
Overall height	3.94 in
Overall width	2.87 in

HOUSING

Housing Material	Polyamide
Fork shape	Twin wheel housing
Swivel bearing	Stem, swiveling
Housing Color	Gray white (RAL9002)
Swivel radius	3.46 in
Swivel interference	6.93 in
Dome diameter	1.57 in

WHEEL

Body material	Polyamide
Tread material	Polyurethane, injected
Bearing	Precision ball bearing
Threadguards	With threadguard
Diameter	3.94 in
Tread width	0.79 in

FITTING

Fitting type	Blind hole for B10 fitting
Bolt hole diameter	0.43 in



Deutscher Designer Club



Interzum Award



IF Design Award

product design award

LINEA SAFETY

592DUAP100L51-11 RAL9002

EAN 4031582415353



BETTER MOBILITY. BETTER LIFE.

Product Drawings

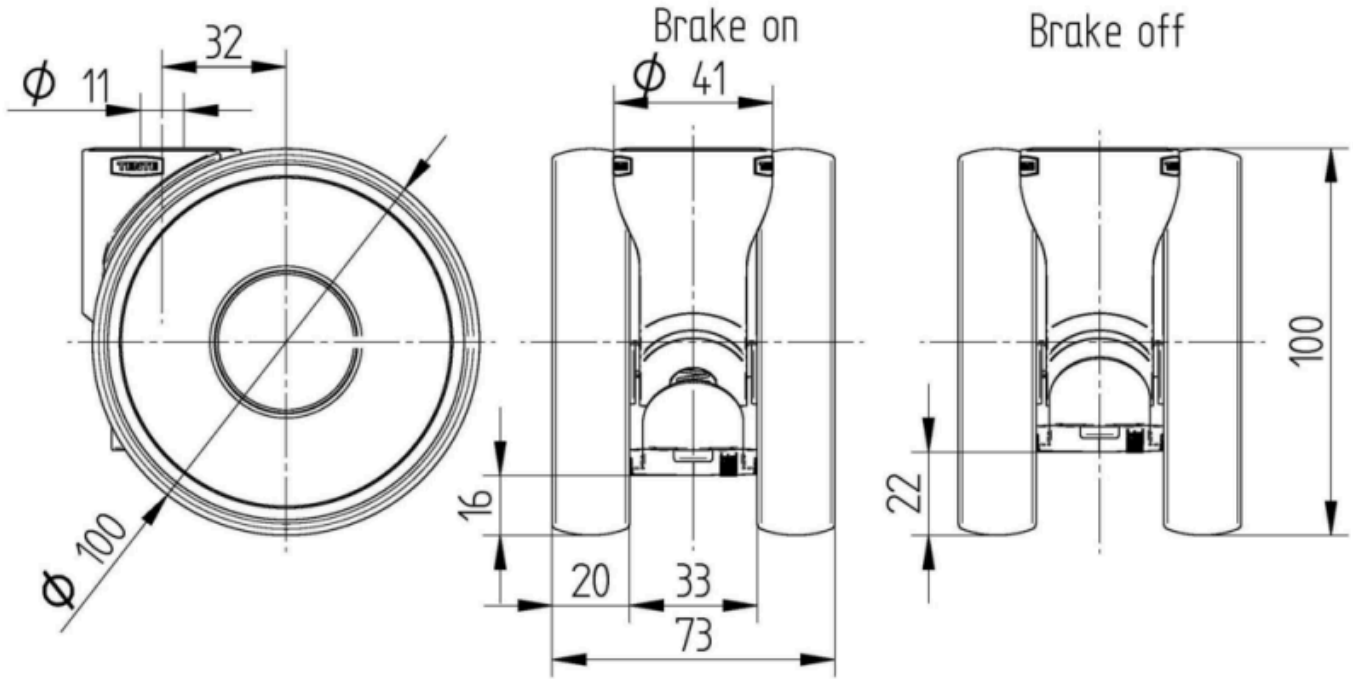

Deutscher
Designer
Club



Interzum
Award



product
design
award

IF Design
Award