

AVIANA

5976UAE075P54 LIGHT 7001 BK+WASHER

EAN 4031582396638



BETTER MOBILITY. BETTER LIFE.



Image may differ from the original product

PERFORMANCE

Roll performance	●●●○○
Movement noise	●●●○○
Attrition	●●●●○
Corrosion resistance	●●●●●

CORE ATTRIBUTES

Product name	Aviana
Type	Swivel castor with central , total lock
Standard	EN12530 - Devices Castors
Load capacity at 1.8 mph	220.46 lb
Load capacity Static	440.92 lb
Temperature range (Minimum)	14 °F
Temperature range (Maximum)	104 °F
Overall height	4.02 in
Overall width	2.72 in
Overall weight	0.82 lb

WHEEL

Body material	Polyamide
Tread material	Polyurethane, injected
Bearing	Cone ball bearing, stainless
Wheel color	Slate gray (RAL7015)
Diameter	2.95 in
Tread width	0.98 in
Body width	0.98 in
Hardness of tread (A)	92 Shore A
Hardness of tread (D)	42 Shore D

HOUSING

Material	Polyamide
Fork shape	Twin wheel housing
Swivel bearing	Two ball races
Color	Silver gray (RAL7001)
Offset	1.1 in
Swivel radius	2.7 in
Swivel interference	5.39 in
Dome diameter	2.13 in

FITTING

Fitting type	Rectangular plate with brake elements
Plate length	2.76 in
Plate width	2.17 in
Plate hole length (Minimum)	2.01 in
Plate hole length (Maximum)	1.61 in
Plate hole width (Minimum)	2.01 in
Plate hole width (Maximum)	2.24 in
Plate hole diameter	0.22 in



Red Dot
Design
Award



German
Design
Award

AVIANA

5976UAE075P54 LIGHT 7001 BK+WASHER

EAN 4031582396638



BETTER MOBILITY. BETTER LIFE.

TECHNICAL DRAWINGS

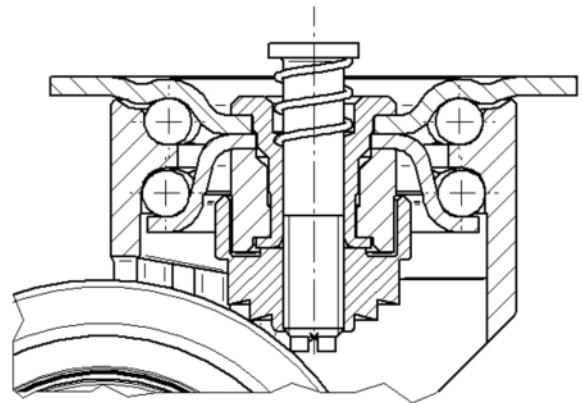
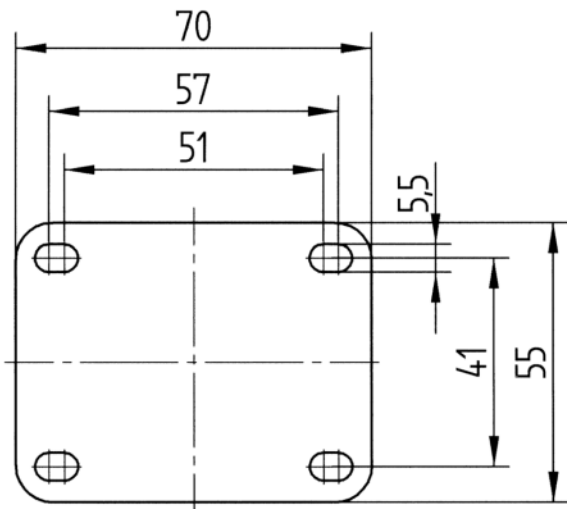
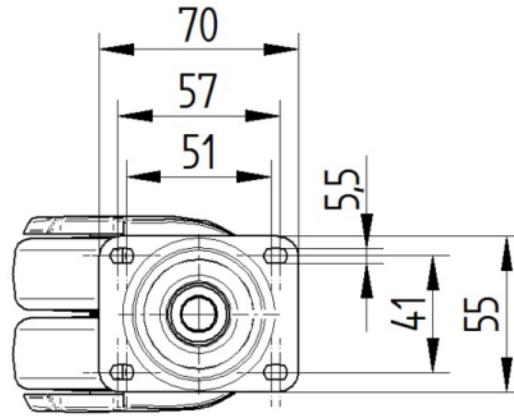
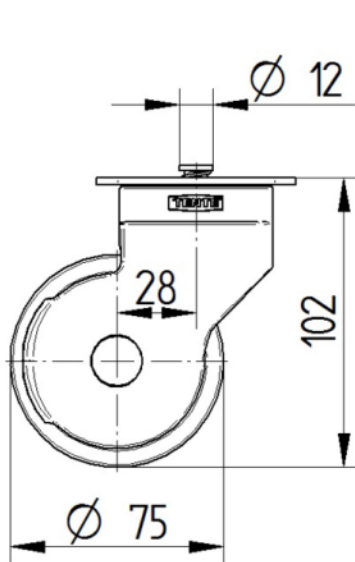

Red Dot
Design
Award



German
Design
Award