

# NOVATECH

FTP 250x100-Ø35 HL120

EAN 4031582319361



BETTER MOBILITY. BETTER LIFE.



Image may differ from the original product

## WHEEL

Body material	Cast iron
Tread Material Mix	Polyurethane, casted
Bearing	Precision ball bearing
Wheel Color	Honey yellow (RAL1005)
Threadguards	With threadguard
Diameter	250 mm
Tread width	100 mm
Axle Hole Diameter	35 mm
Hub Length	120 mm
Body width	100 mm
Hardness of tread (A)	92 Shore A
Hardness of tread (D)	42 Shore D

## PERFORMANCE

Roll Performance	●●●●○
Movement Noise	●●●○○
Attrition	●●●●○
Corrosion Resistance	●●●○○

## CORE ATTRIBUTES

Product Name	Novatech
Type	Wheel
Standard	EN12533 - Heavy Duty Castors
Load capacity at 4 km/h	2640 kg
Load capacity at 6 km/h	2200 kg
Electric Conductive	No
Stainless	No
Load capacity Static	4400 kg
Temperature range (Minimum)	-10 °C
Temperature range (Maximum)	60 °C
Overall weight	15.06 kg

# NOVATECH

FTP 250x100-Ø35 HL120

EAN 4031582319361

Order number 00801911

Product Drawings



BETTER MOBILITY. BETTER LIFE.

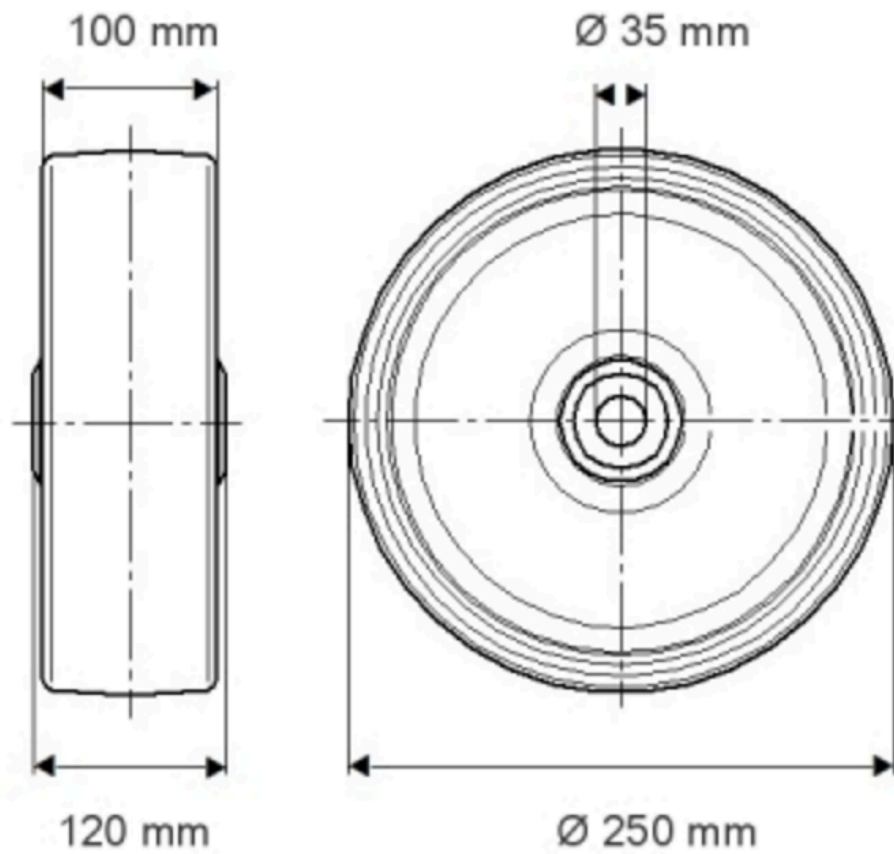

PRODUCT INFORMATION

# NOVATECH

FTP 250x100-Ø35 H1.120

EAN 4031582319361

Order number 00801911

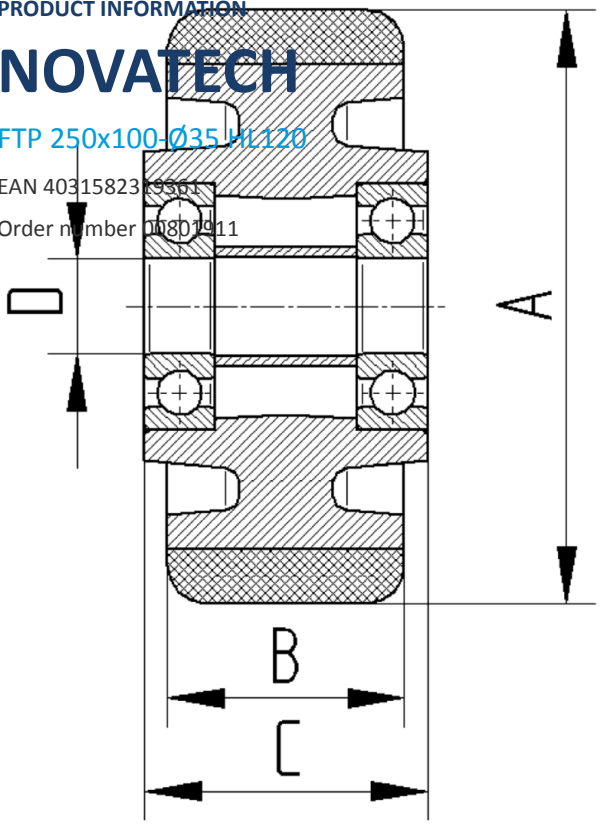

BETTER MOBILITY. BETTER LIFE.