

LEVINA

5370XSP125P30-11 WINDOW-GREY

EAN 4031582359251
Order number 00036394



BETTER MOBILITY. BETTER LIFE.



Image may differ from the original product

PERFORMANCE

Roll performance	●●●○○
Movement noise	●●●○○
Attrition	●●●●○
Corrosion resistance	●●●○○

CORE ATTRIBUTES

Product name	Levina
Type	Swivel castor
Standard	EN12530 - Devices Castors
Load capacity at 3 km/h	100 kg
Electric conductive	✓
Load capacity Static	200 kg
Temperature range (Minimum)	-10 °C
Temperature range (Maximum)	40 °C
Overall height	161 mm
Overall width	59 mm
Overall weight	0.602 kg

WHEEL

Body material	Polyamide, electric conductive
Tread material	Polyurethane, injected, electric-conductive
Bearing	Precision ball bearing
Wheel color	Silver grey (RAL7001)
Threadguards	With threadguard
Diameter	125 mm
Tread width	32 mm
Body width	32 mm
Hardness of tread (A)	91 Shore A
Hardness of tread (D)	40 Shore D

HOUSING

Material fork	Polyamide
Fork shape	Slim
Swivel bearing	Two ball races
Colour	Window grey (similar RAL7040)
Offset	38 mm
Swivel radius	100.5 mm
Swivel interference	201 mm
Dome diameter	59 mm

FITTING

Fitting type	Bolt hole
Bolt hole diameter	11 mm



Universal Design Award



Deutscher Designer Club

LEVINA

5370XSP125P30-11 WINDOW-GREY

EAN 4031582359251
Order number 00036394



BETTER MOBILITY. BETTER LIFE.

TECHNICAL DRAWINGS

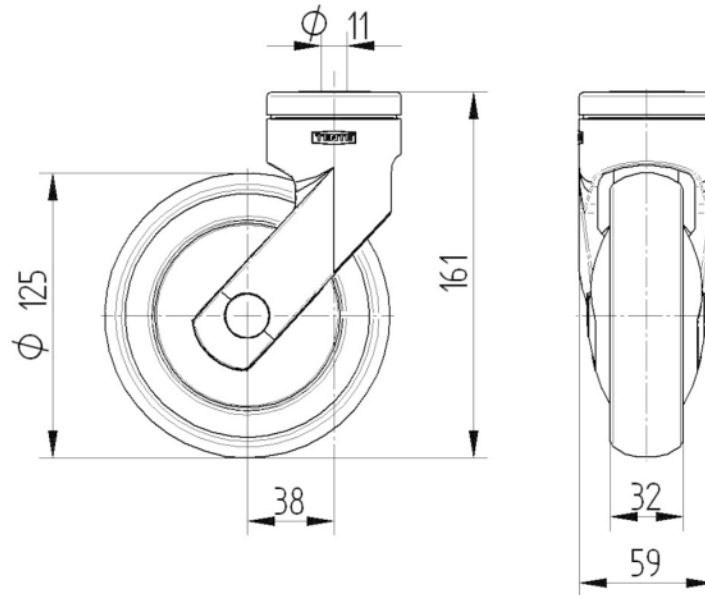

Universal
Design
Award



Deutscher
Designer
Club