

# LINEA

5940UAP100P51 RAL9002

EAN 4031582352108



BETTER MOBILITY. BETTER LIFE.



Afbeelding kan afwijken van het oorspronkelijke product

## PRESTATIES

|                       |           |
|-----------------------|-----------|
| Rolprestaties         | ● ● ● ● ● |
| Bewegingsgeluid       | ● ● ● ○ ○ |
| Slijtage              | ● ● ● ● ○ |
| Corrosiebestendigheid | ● ● ● ● ○ |

## KERNKENMERKEN

|                              |                                    |
|------------------------------|------------------------------------|
| Productnaam                  | Linea                              |
| Type                         | Wielen                             |
| Standaard                    | EN12530 - Hulpmiddelen zwenkwielen |
| Draagvermogen bij 3 km/h     | 120 kg                             |
| Statisch draagvermogen       | 240 kg                             |
| Temperatuurbereik (minimaal) | -10 °C                             |
| Temperatuurbereik (maximaal) | 40 °C                              |
| Totale hoogte                | 124 mm                             |
| Totale breedte               | 82 mm                              |

## WIEL

|                               |                        |
|-------------------------------|------------------------|
| Materiaal wielkern            | Polyamide              |
| Materiaal loopvlak            | Polyurethaan, Gespoten |
| Lagering                      | Precisie kogellagers   |
| Afdekkapjes                   | Met draadbeschermer    |
| Diameter                      | 100 mm                 |
| Breedte Loopvlak              | 20 mm                  |
| Hardheid van het Loopvlak (A) | 92 Shore A             |

## BEHUIZING

|                 |                         |
|-----------------|-------------------------|
| Materiaal       | Polyamide               |
| Vork Vorm       | Behuizing met twee Wiel |
| Zwenklager      | Precisie kogellagers    |
| Kleur           | Grijs wit (RAL9002)     |
| Offset          | 32 mm                   |
| Zwenk radius    | 90 mm                   |
| Draaicirkel     | 180 mm                  |
| Diameter koepel | 52 mm                   |

## FITTING

|                             |                    |
|-----------------------------|--------------------|
| Type bevestiging            | Rechthoekige plaat |
| Lengte plaat                | 95 mm              |
| Breedte plaat               | 70 mm              |
| Lengte plaatgat (maximaal)  | 75 mm              |
| Breedte plaatgat (maximaal) | 50 mm              |
| Diameter plaatgat           | 11 mm              |



Deutscher  
Ontwerper  
Club



Interzum  
Award



IF  
Design  
Award

# LINEA

5940UAP100P51 RAL9002

EAN 4031582352108



BETTER MOBILITY. BETTER LIFE.

## TECHNISCHE TEKENINGEN

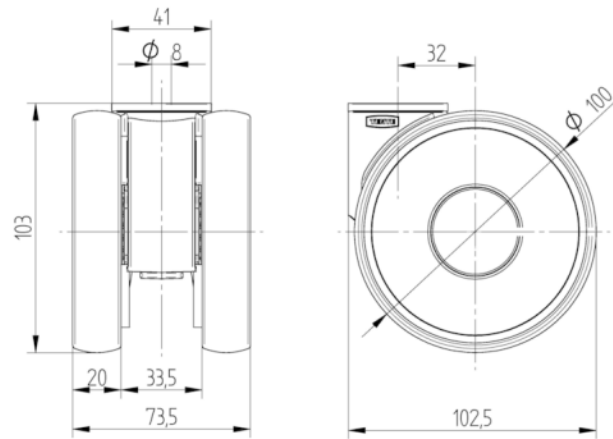

Deutscher  
Ontwerper  
Club



Interzum  
Award



IF  
Design  
Award