

# DURATECH

MOP125x50-Ø25

EAN 4031582482126



BETTER MOBILITY. BETTER LIFE.



Image may differ from the original product

## WHEEL

Body material	Polyamide, super heavy
Tread Material Mix	Identical with wheel body
Bearing	Precision ball bearing
Threadguards	Without threadguard
Diameter	125 mm
Tread width	50 mm
Axle Hole Diameter	25 mm
Hub Length	60 mm
Hardness of tread (D)	75 Shore D
Bearing type	6304

## PERFORMANCE

Roll Performance	● ● ● ● ●
Movement Noise	● ● ● ○ ○
Attrition	● ● ● ● ●
Corrosion Resistance	● ● ● ○ ○

## CORE ATTRIBUTES

Product Name	Duratech
Type	Wheel
Standard	EN12533 - Heavy Duty Castors
Load capacity at 4 km/h	2040 kg
Electric Conductive	No
Stainless	No
Load capacity Static	4080 kg
Temperature range (Minimum)	-40 °C
Temperature range (Maximum)	80 °C
Overall weight	1.11 kg

# DURATECH

MOP125x50-Ø25

EAN 4031582482126



BETTER MOBILITY. BETTER LIFE.

## Product Drawings

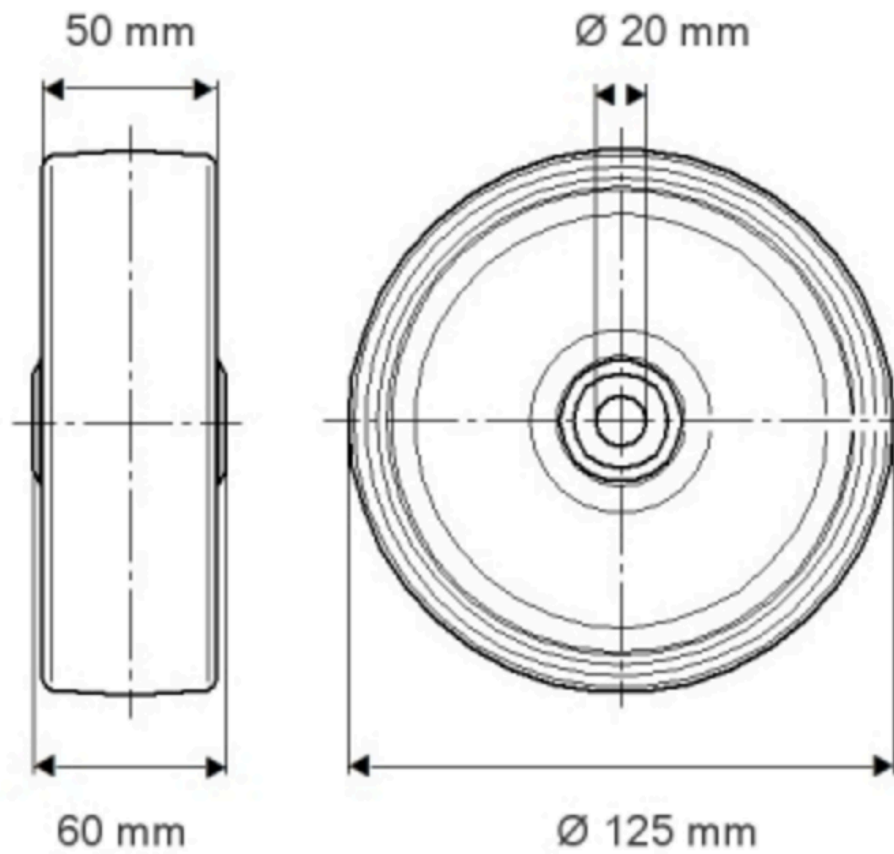

PRODUCT INFORMATION

# DURATECH

MOP125x50-Ø25

EAN 4031582482126

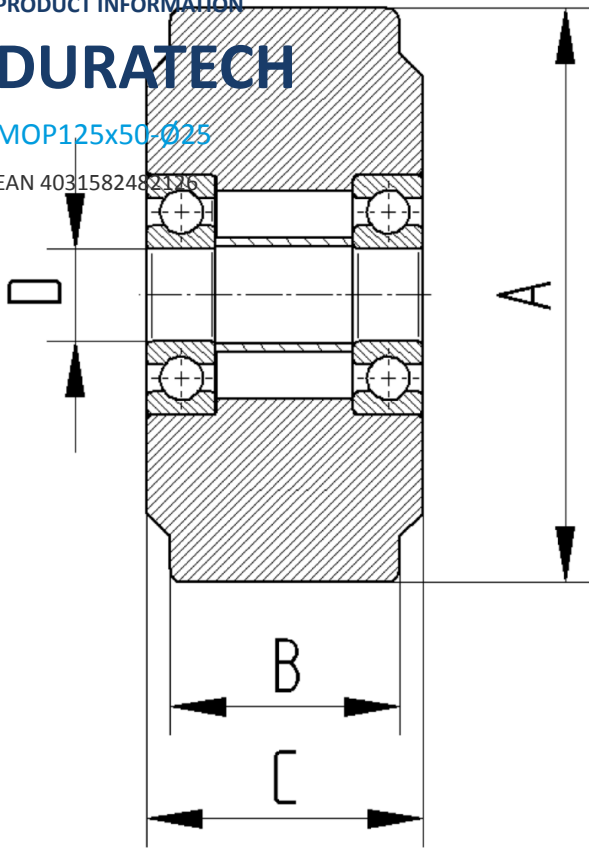

BETTER MOBILITY. BETTER LIFE.