

# INTEGRAL TWIN

2944UAP125R26-28S45 D 9002 4XM8

EAN 4031582302547  
Order number 00032918



BETTER MOBILITY. BETTER LIFE.



Image may differ from the original product

## PERFORMANCE

Roll performance	● ● ● ● ●
Movement noise	● ● ● ○ ○
Attrition	● ● ● ● ○
Corrosion resistance	● ● ● ○ ○

## CORE ATTRIBUTES

Product name	Integral twin
Type	Swivel castor with central, total or directional lock
Standard	EN12531 - Hospital Bed Castors
Load capacity at 1.8 mph	275.58 lb
Load capacity at 2.5 mph	275.58 lb
Load capacity Static	826.73 lb
Temperature range (Minimum)	-13 °F
Temperature range (Maximum)	176 °F
Overall height	5.91 in
Overall width	2.48 in
Overall weight	2.56 lb
Certification	Tested and monitored by TÜV Süd

## WHEEL

Body material	Polyamide
Tread material	Polyurethane, injected
Bearing	Precision ball bearing
Wheel color	Gray white (RAL9002)
Threadguards	With threadguard
Diameter	4.92 in
Tread width	0.47 in
Body width	0.47 in
Hardness of tread (A)	92 Shore A
Hardness of tread (D)	42 Shore D

## HOUSING

Material	Steel sheet, medium
Fork shape	Twin wheel housing
Swivel bearing	Precision ball bearing
Color	Gray white (RAL9002)
Offset	1.48 in
Swivel radius	4.06 in
Swivel interference	8.11 in
Dome diameter	2.42 in

## FITTING

Fitting type	Stem with cam hole for profile bars
Bolt diameter	1.1 in
Bolt length	3.78 in
Bolt thread position	0.75 in
Bolt mounting holes quantity	4



German Design Award



Red Dot Design Award

# INTEGRAL TWIN

2944UAP125R26-28S45 D 9002 4XM8

EAN 4031582302547  
Order number 00032918



BETTER MOBILITY. BETTER LIFE.

## TECHNICAL DRAWINGS

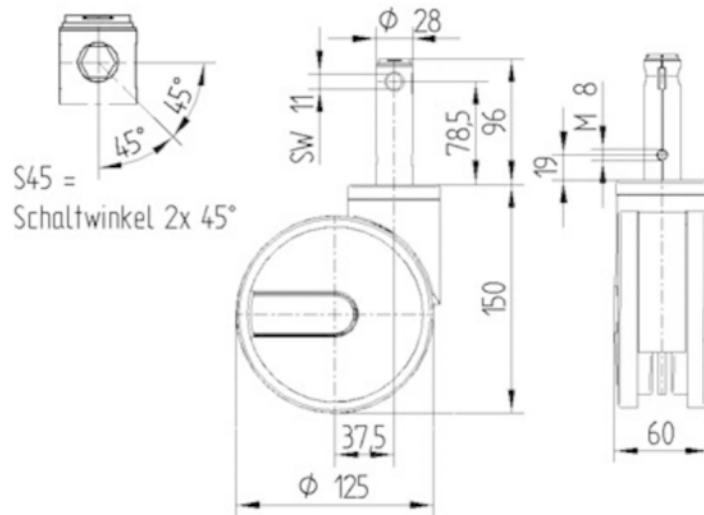

German  
Design  
Award



Red Dot  
Design  
Award