

# LINEA

5940UAP100P51 RAL9002

EAN 4031582352108



BETTER MOBILITY. BETTER LIFE.



Image may differ from the original product

## PERFORMANCE

Roll performance	● ● ● ● ●
Movement noise	● ● ● ○ ○
Attrition	● ● ● ● ○
Corrosion resistance	● ● ● ● ○

## CORE ATTRIBUTES

Product name	Linea
Type	Swivel castor
Standard	EN12530 - Devices Castors
Load capacity at 1.8 mph	264.55 lb
Load capacity Static	529.11 lb
Temperature range (Minimum)	14 °F
Temperature range (Maximum)	104 °F
Overall height	4.88 in
Overall width	3.23 in

## WHEEL

Body material	Polyamide
Tread material	Polyurethane, injected
Bearing	Precision ball bearing
Threadguards	With threadguard
Diameter	3.94 in
Tread width	0.79 in
Hardness of tread (A)	92 Shore A

## HOUSING

Material	Polyamide
Fork shape	Twin wheel housing
Swivel bearing	Precision ball bearing
Color	Gray white (RAL9002)
Offset	1.26 in
Swivel radius	3.54 in
Swivel interference	7.09 in
Dome diameter	2.05 in

## FITTING

Fitting type	Rectangular plate
Plate length	3.74 in
Plate width	2.76 in
Plate hole length (Maximum)	2.95 in
Plate hole width (Maximum)	1.97 in
Plate hole diameter	0.43 in



# LINEA

5940UAP100P51 RAL9002

EAN 4031582352108



BETTER MOBILITY. BETTER LIFE.

## TECHNICAL DRAWINGS

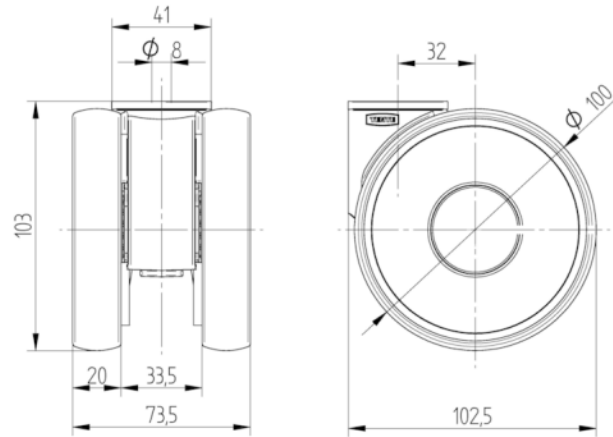

Deutscher  
Designer  
Club



Interzum  
Award



IF  
Design  
Award