

LINEA

5940XSP125P51 RAL9002

EAN 4031582352191



BETTER MOBILITY. BETTER LIFE.



Image may differ from the original product

PERFORMANCE

Roll performance	● ● ● ● ●
Movement noise	● ● ● ○ ○
Attrition	● ● ● ● ○
Corrosion resistance	● ● ● ● ○

CORE ATTRIBUTES

Product name	Linea
Type	Swivel castor
Standard	EN12530 - Devices Castors
Load capacity at 3 km/h	130 kg
Electric conductive	✓
Load capacity Static	260 kg
Temperature range (Minimum)	-10 °C
Temperature range (Maximum)	40 °C
Overall height	148 mm
Overall width	82 mm

WHEEL

Body material	Polyamide, electric conductive
Tread material	Polyurethane, injected, electric-conductive
Bearing	Precision ball bearing
Threadguards	With threadguard
Diameter	125 mm
Tread width	20 mm
Hardness of tread (A)	92 Shore A

HOUSING

Material fork	Polyamide
Fork shape	Twin wheel housing
Swivel bearing	Precision ball bearing
Colour	Grey white (RAL9002)
Offset	40 mm
Swivel radius	109 mm
Swivel interference	218 mm
Dome diameter	52 mm

FITTING

Fitting type	Rectangular plate
Plate length	95 mm
Plate width	70 mm
Plate hole length (Maximum)	75 mm
Plate hole width (Maximum)	50 mm
Plate hole diameter	11 mm



Deutscher Designer Club



Interzum Award



IF Design Award

PRODUCT INFORMATION

LINEA

5940XSP125P51 RAL9002

EAN 4031582352191



BETTER MOBILITY. BETTER LIFE.

TECHNICAL DRAWINGS

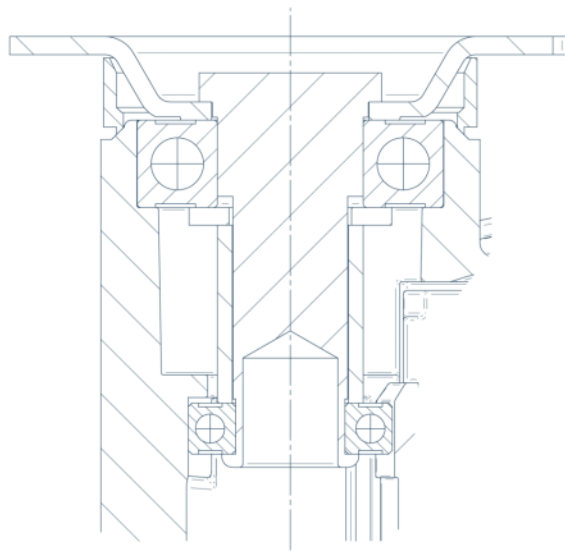

Deutscher
Designer
Club



Interzum
Award



IF
Design
Award