

LEVINA

5371PJP100P50 7001/6032

EAN 4031582358698
Order number 00038168



BETTER MOBILITY. BETTER LIFE.



Image may differ from the original product

PERFORMANCE

Roll performance	● ● ● ○ ○
Movement noise	● ● ● ● ●
Attrition	● ● ● ○ ○
Corrosion resistance	● ● ● ● ○

CORE ATTRIBUTES

Product name	Levina
Type	Swivel castor with directional lock
Standard	EN12530 - Devices Castors
Load capacity at 3 km/h	100 kg
Load capacity Static	200 kg
Temperature range (Minimum)	-10 °C
Temperature range (Maximum)	40 °C
Overall height	137 mm
Overall width	59 mm
Overall weight	0.503 kg

WHEEL

Body material	Polypropylene
Tread material	Thermoplastic rubber
Bearing	Precision ball bearing
Wheel color	Silver grey (RAL7001)
Threadguards	With threadguard
Diameter	100 mm
Tread width	32 mm
Body width	32 mm
Hardness of tread (A)	87 Shore A

HOUSING

Material fork	Polyamide
Fork shape	Slim
Swivel bearing	Two ball races
Colour	Silver grey (RAL7001)
Offset	36 mm
Swivel radius	98 mm
Swivel interference	196 mm
Dome diameter	59 mm

FITTING

Fitting type	Rectangular plate
Plate length	77 mm
Plate width	67 mm
Plate hole length (Minimum)	46.5 mm
Plate hole length (Maximum)	51.5 mm
Plate hole width (Minimum)	56 mm
Plate hole width (Maximum)	61.5 mm
Plate hole diameter	8.5 mm



LEVINA

5371PJP100P50 7001/6032

EAN 4031582358698
Order number 00038168



BETTER MOBILITY. BETTER LIFE.

TECHNICAL DRAWINGS

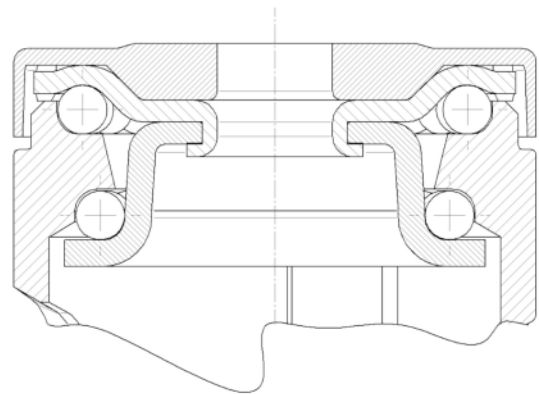
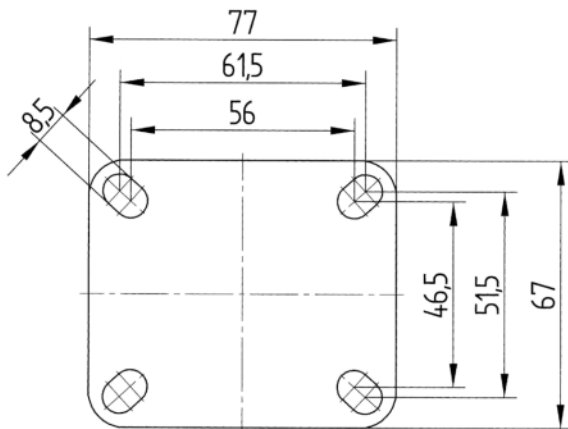
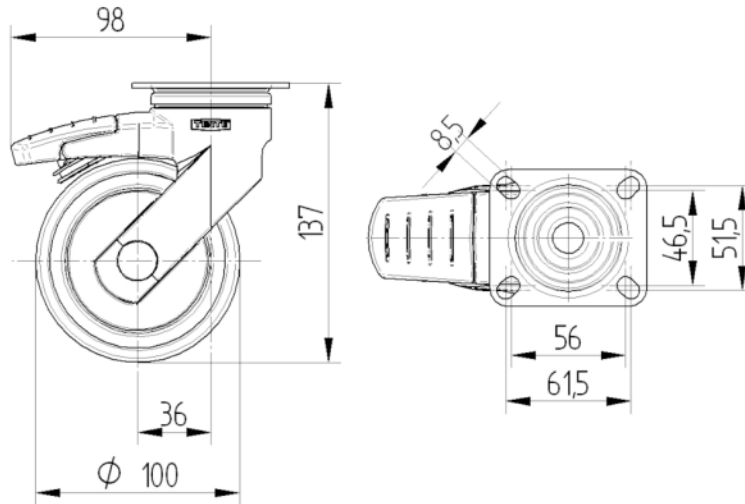

Universal
Design
Award



Deutscher
Designer
Club