

LINEA

594CUAP125P30-11 RAL7001

EAN 4031582378306
Order number 00772241



BETTER MOBILITY. BETTER LIFE.



Image may differ from the original product

PERFORMANCE

Roll performance	● ● ● ● ●
Movement noise	● ● ● ○ ○
Attrition	● ● ● ● ○
Corrosion resistance	● ● ● ● ○

CORE ATTRIBUTES

Product name	Linea
Type	Swivel castor with combined lock
Standard	EN12530 - Devices Castors
Load capacity at 1.8 mph	286.6 lb
Load capacity Static	573.2 lb
Temperature range (Minimum)	-4 °F
Temperature range (Maximum)	140 °F
Overall height	5.63 in
Overall width	3.23 in
Overall weight	2.17 lb
Certification	Tested and monitored by TÜV Süd

WHEEL

Body material	Polyamide
Tread material	Polyurethane, injected
Bearing	Precision ball bearing
Threadguards	With threadguard
Diameter	4.92 in
Tread width	0.79 in
Hardness of tread (A)	92 Shore A

HOUSING

Material	Polyamide
Fork shape	Twin wheel housing
Swivel bearing	Precision ball bearing
Color	Silver gray (RAL7001)
Offset	1.57 in
Swivel radius	5.08 in
Swivel interference	10.16 in
Dome diameter	2.05 in

FITTING

Fitting type	Bolt hole
Bolt hole diameter	0.43 in



LINEA

594CUAP125P30-11 RAL7001

EAN 4031582378306
Order number 00772241



BETTER MOBILITY. BETTER LIFE.

TECHNICAL DRAWINGS

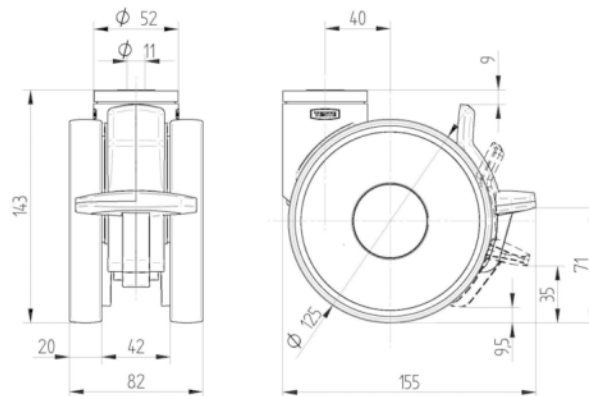

Deutscher
Designer
Club



Interzum
Award



IF
Design
Award