

INTEGRAL TWIN

2946UAP125R26-28S45 4XM8

EAN 4031582443318



BETTER MOBILITY. BETTER LIFE.



Image may differ from the original product

PERFORMANCE

Roll performance	● ● ● ● ●
Movement noise	● ● ● ○ ○
Attrition	● ● ● ● ○
Corrosion resistance	● ● ● ○ ○

CORE ATTRIBUTES

Product name	Integral twin
Type	Swivel castor with central, total lock
Standard	similar EN12531- Hospital Bed Castors
Load capacity at 3 km/h	125 kg
Load capacity at 4 km/h	125 kg
Load capacity Static	250 kg
Temperature range (Minimum)	-30 °C
Temperature range (Maximum)	80 °C
Overall height	150 mm
Overall width	60 mm
Overall weight	1.171 kg
Certification	Tested and monitored by TÜV Süd

WHEEL

Body material	Polyamide
Tread material	Polyurethane, injected
Bearing	Precision ball bearing
Threadguards	With threadguard
Diameter	125 mm
Tread width	12 mm
Hardness of tread (D)	42 Shore D

HOUSING

Material fork	Steel sheet, medium
Fork shape	Twin wheel housing
Swivel bearing	Precision ball bearing
Offset	37.5 mm
Swivel radius	100 mm
Swivel interference	200 mm

FITTING

Brake cam	hex cam
Fitting type	Stem with cam hole for profile bars
Bolt diameter	28 mm
Bolt length	96 mm



German Design Award



Red Dot Design Award

INTEGRAL TWIN

2946UAP125R26-28S45 4XM8

EAN 4031582443318



BETTER MOBILITY. BETTER LIFE.

TECHNICAL DRAWINGS

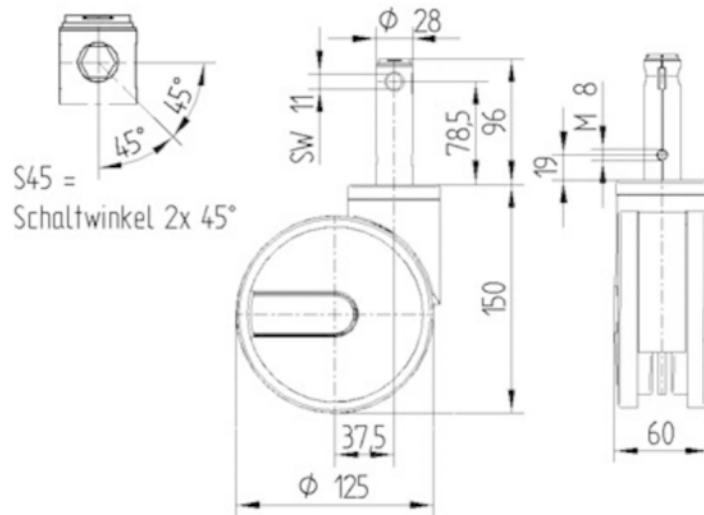

German
Design
Award



Red Dot
Design
Award