

LINEA SAFETY

592DUAP100L51-11 RAL9002

EAN 4031582415353



BETTER MOBILITY. BETTER LIFE.



Image non contractuelle, peut différer du produit d'origine

PERFORMANCE

Performance de roulage	● ● ● ● ○ ○
Bruit de mouvement	● ● ● ● ○ ○
Usure	● ● ● ● ○ ○
Résistance à la corrosion	● ● ● ● ○ ○

ATTRIBUTS PRINCIPAUX

Nom du produit	Linea safety
Type	Système de blocage automatique
Norme	EN12528 - Roulettes d'ameublement
Capacité de charge à 3 km/h	100 kg
Conducteur d'électricité	Non
Inoxydable	Non
Capacité de charge statique	200 kg
Plage de température (minimale)	-20 °C
Plage de température (maximale)	60 °C
Hauteur	100 mm
Largeur totale	73 mm

CHAPE

Matériau de la chape	Polyamide
Forme de la chape	Roulette jumelée
Pivot	Tige pivotante
Couleur de la chape	Blanc gris (RAL9002)
Rayon d'encombrement	88 mm
Diamètre d'encombrement	176 mm
Diamètre du dôme	40 mm

ROUE

Corps de roue	Polyamide
Bandage	Polyuréthane, injecté
Roulement	Roulement à billes de précision
Pare-fils	Avec pare-fils
Diamètre	100 mm
Largeur du bandage	20 mm

FIXATION

Type de fixation	Trou borgne pour fixation B10
Diamètre du trou central	11 mm

Deutscher
Designer
ClubInterzum
Awardproduct
design
awardIF Design
Award

LINEA SAFETY

592DUAP100L51-11 RAL9002

EAN 4031582415353



BETTER MOBILITY. BETTER LIFE.

Product Drawings

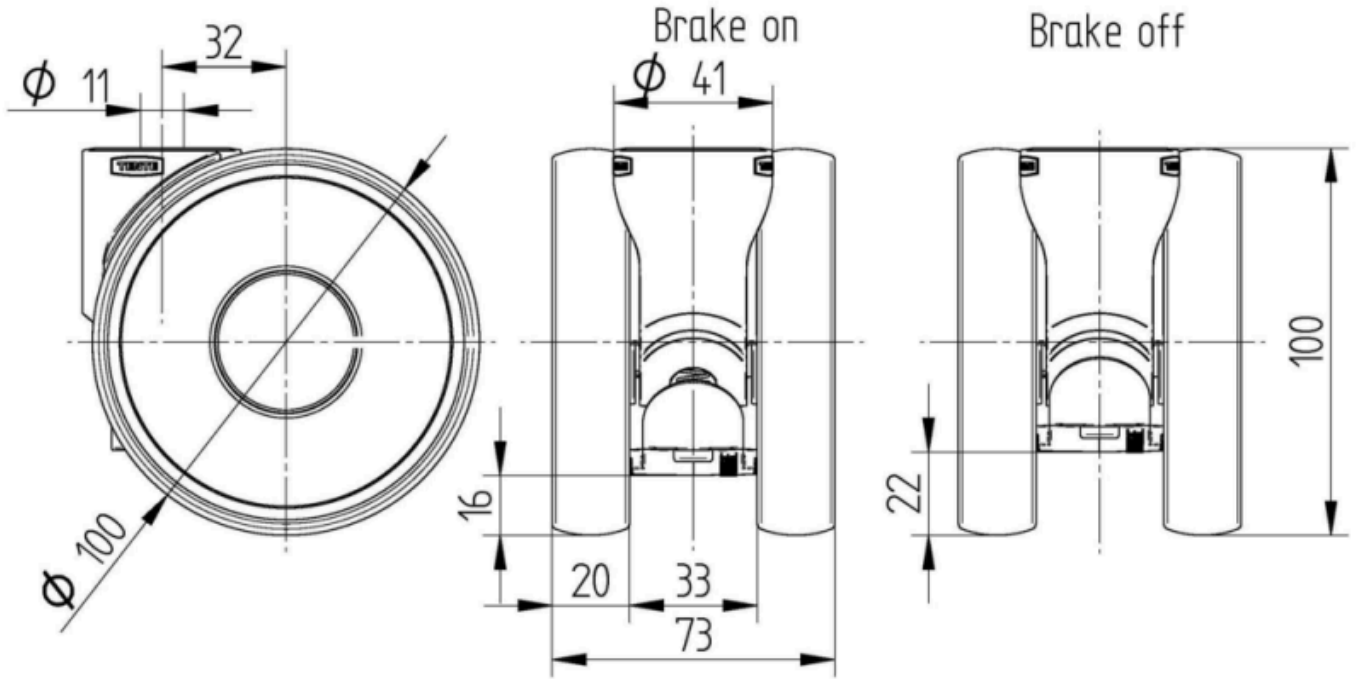

Deutscher
Designer
Club



Interzum
Award



product
design
award

IF Design
Award