

# LINEA LIGHT

5925POH065L51-10

EAN 4031582404005



BETTER MOBILITY. BETTER LIFE.



Image may differ from the original product

## PERFORMANCE

Roll performance	● ● ● ○ ○
Movement noise	● ● ● ○ ○
Attrition	● ● ● ○ ○
Corrosion resistance	● ● ● ● ○

## CORE ATTRIBUTES

Product name	Linea light
Type	Swivel castor with wheel brake
Standard	EN12528 - Furniture Castors
Load capacity at 1.8 mph	88.18 lb
Load capacity Static	176.37 lb
Temperature range (Minimum)	14 °F
Temperature range (Maximum)	104 °F
Overall height	2.68 in
Overall width	1.81 in
Overall weight	0.2 lb

## WHEEL

Body material	Polypropylene
Tread material	Identical with wheel body
Bearing	Plain bearing
Threadguards	With threadguard
Diameter	2.56 in
Tread width	0.55 in

## HOUSING

Material	Polyamide
Fork shape	Twin wheel housing
Swivel bearing	Stem, swiveling
Swivel radius	2.64 in
Swivel interference	5.28 in
Dome diameter	0.91 in

## FITTING

Fitting type	Blind hole for B10 fitting
Bolt hole diameter	0.39 in



# LINEA LIGHT

5925POH065L51-10

EAN 4031582404005



BETTER MOBILITY. BETTER LIFE.

## TECHNICAL DRAWINGS

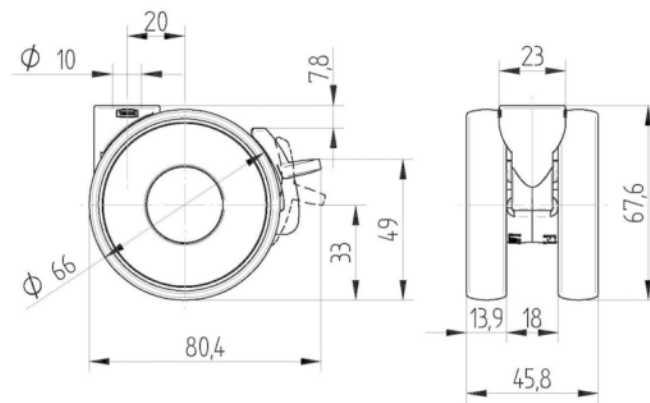

Deutscher  
Designer  
Club



Interzum  
Award



IF  
Design  
Award