

LINEA LIGHT

5925XSP100L51-11 RAL9002

EAN 4031582370751



BETTER MOBILITY. BETTER LIFE.



Afbeelding kan afwijken van het oorspronkelijke product

PRESTATIES

Rolprestaties	● ● ● ○ ○
Bewegingsgeluid	● ● ● ○ ○
Slijtage	● ● ● ○ ○
Corrosiebestendigheid	● ● ● ● ○

KERNKENMERKEN

Productnaam	Linea light
Type	Wielen met Wielslot
Standaard	EN12528 - Meubel wielen
Draagvermogen bij 3 km/h	100 kg
Elektrisch geleidend	✓
Statisch draagvermogen	200 kg
Temperatuurbereik (minimaal)	-10 °C
Temperatuurbereik (maximaal)	40 °C
Totale hoogte	100 mm
Totale breedte	73 mm

WIEL

Materiaal wielkern	Polyamide, elektrisch geleidend
Materiaal loopvlak	Polyurethaan, Gespoten elektrisch geleidend
Lagering	Precisie kogellagers
Loopvlak	Leigrijs (RAL7015)
Wielkleur	Leigrijs (RAL7015)
Afdekkapjes	Met draadbeschermer
Diameter	100 mm
Breedte Loopvlak	20 mm
Breedte wielkern	20 mm
Hardheid van het Loopvlak (A)	92 Shore A

BEHUIZING

Materiaal	Polyamide
Vork Vorm	Behuizing met twee Wiel
Zwenklager	Kraagpen, draaiend
Kleur	Zilvergrijs (RAL7001)
Offset	32 mm
Zwenk radius	102 mm
Draaicirkel	204 mm
Diameter koepel	41 mm

FITTING

Type bevestiging	Blind gat voor B10-fitting
Boutgat diameter	11 mm



Deutscher
Ontwerper
Club



Interzum
Award



IF
Design
Award

LINEA LIGHT

5925XSP100L51-11 RAL9002

EAN 4031582370751



BETTER MOBILITY. BETTER LIFE.

TECHNISCHE TEKENINGEN

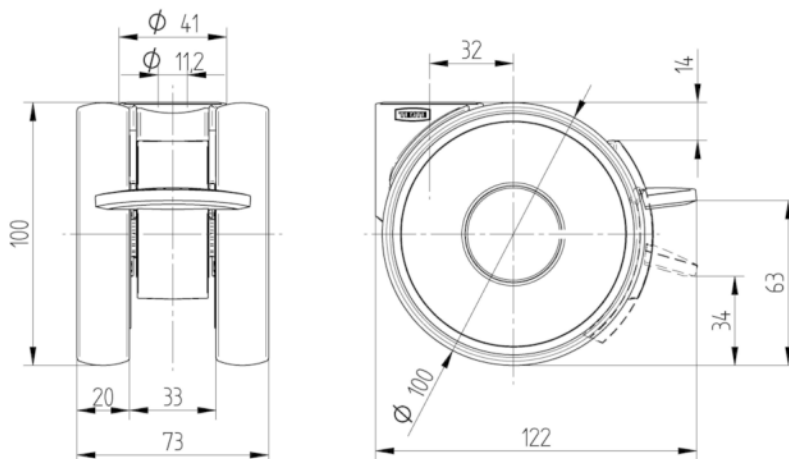

Deutscher
Ontwerper
Club



Interzum
Award



IF
Design
Award